

HIDALGO COUNTY REGIONAL MOBILITY AUTHORITY

NOTICE OF AND AGENDA FOR A WORKSHOP AND A REGULAR MEETING TO BE HELD BY THE BOARD OF DIRECTORS

DATE: TUESDAY, JUNE 25, 2024
TIME: 5:30 PM
PLACE: PHARR CITY HALL
2nd FLOOR CITY COMMISSION CHAMBERS
118 SOUTH CAGE BLVD.
PHARR, TEXAS 78577

PRESIDING: S. DAVID DEANDA, JR, CHAIRMAN

An electronic copy of the agenda packet can be obtained at www.hcrma.net

PLEDGE OF ALLEGIANCE

INVOCATION

CALL TO ORDER OF A WORKSHOP

1. Hidalgo County Regional Mobility Authority Board of Directors Annual Ethics and Compliance Training.

ADJOURNMENT OF WORKSHOP

CALL TO ORDER AND ESTABLISHMENT OF A QUORUM FOR A REGULAR MEETING

PUBLIC COMMENT

1. REPORTS

- A. Report on Program Management Activity for 365 Tollway Project – HCRMA Staff
- B. Report on Construction Activity for 365 Tollway Project – Ramon Navarro IV, HCRMA.

2. **CONSENT AGENDA** *(All matters listed under Consent Agenda are considered to be routine by the Governing Body and will be enacted by one motion. There will be no separate discussion of these items; however, if discussion is desired, that item(s) will be removed from the Consent Agenda and will be considered separately. The Governing Body may also elect to go into Executive Session on any item on this agenda, whether or not such item(s) are posted as an Executive Session Item, at any time during the meeting when authorized by provisions of the Open Public Meeting Act.)*

- A. Approval of Minutes for the Regular Board Meeting held May 28, 2024.
- B. Approval of Project & General Expense Report for the period from May 8, 2024, to June 7, 2024.
- C. Approval of Financial Reports for May 2024.

3. REGULAR AGENDA

- A. Resolution 2024-27 – Consideration and Approval of Change Order Number 6 to that Certain Construction Contract with Pulice Construction, Inc. for the 365 Tollway.
- B. Resolution 2024-29 Consideration and Approval of Supplemental No. 2 to Work Authorization Number 21 to the Professional Service agreement with SAMES, Inc. for a no-cost time extension to provide Surveying services for additional “X” Parcels claimed by Hidalgo County Irrigation District Number 2 as part of the 365 Tollway Project.
- C. Resolution 2024-30 Consideration and Approval of Supplemental Number 3 to Work Authorization Number 8 with HDR Engineering, Inc. to provide Construction Inspection Services for the 365 Tollway Construction Project.
- D. Resolution 2024-31 Consideration and Approval of Contract Amendment Number 11 with HDR Engineering, Inc. to increase the maximum payable amount for Supplemental Number 3 to Work Authorization number 8.
- E. Resolution 2024-32 Consideration and Approval to proceed with award of contract to MitRes Services, LLC waiving TxDOT precertification requirements for prequalified bidder.

4. CHAIRMAN’S REPORT

- A. None.

5. TABLED ITEMS

- A. None.

6. EXECUTIVE SESSION, CHAPTER 551, TEXAS GOVERNMENT CODE, SECTION 551.071 (CONSULTATION WITH ATTORNEY), SECTION 551.072 (DELIBERATION OF REAL PROPERTY), AND SECTION 551.074 (PERSONNEL MATTERS)

- A. Consultation with Attorney on legal issues pertaining to Change Order Number 5 to that certain contract with Pulice Construction Inc. for the 365 Tollway Project (551.071 T.G.C.)
- B. Consultation with Attorney on legal issues pertaining to the Financial Assistance Agreement with the Texas Department of Transportation for the 365 Tollway Project (551.071 T.G.C.)
- C. Consultation with Attorney on legal issues pertaining to Professional Service Agreements for Inspection, Engineering, Surveying and Environmental Services to include construction material testing (Section 551.071 T.G.C.).
- D. Consultation with Attorney on legal issues pertaining to the voluntary acquisition of real property for various parcels for the 365 Tollway Project and International Bridge Trade Corridor Project (Sections 551.071 and 551.072 T.G.C.).
- E. Consultation with Attorney on legal issues pertaining to the acquisition, including the use of Eminent Domain, for property required to complete the project alignments of the 365 Tollway Project (Sections 551.071 and 551.072 T.G.C.).
- F. Consultation with Attorney on legal issues pertaining to the Environmental Clearance Document for the International Bridge Trade Corridor Project (Section 551.071 T.G.C.).
- G. Consultation with Attorney on legal issues pertaining to Professional Services Agreements (Section 551.071 T.G.C.).

ADJOURNMENT OF REGULAR MEETING

CERTIFICATION

I, the Undersigned Authority, do hereby certify that the attached agenda of the Hidalgo County Regional Mobility Authority Board of Directors is a true and correct copy and that I posted a true and correct copy of said notice on the Hidalgo County Regional Mobility Authority Web Page (www.hcrma.net) and the bulletin board in the Hidalgo County Regional Mobility Authority office (203 W. Newcombe Ave, Pharr, Texas 78577), a place convenient and readily accessible to the general public at all times, and said Notice was posted on the 19th day of **June 2024** at **5:00 pm** and will remain so posted continuously for at least 72 hours preceding the scheduled time of said meeting in accordance with Chapter 551 of the Texas Government Code.

Maria E. Alaniz
Administrative Assistant

Note: If you require special accommodations under the Americans with Disabilities Act, please contact Maria E. Alaniz at 956-402-4762 at least 96 hours before the meeting.

PUBLIC COMMENT POLICY

Public Comment Policy: "At the beginning of each HCRMA meeting, the HCRMA will allow for an open public forum/comment period. This comment period shall not exceed one-half (1/2) hour in length and each speaker will be allowed a maximum of three (3) minutes to speak. Speakers addressing the Board through a translator will be allowed a maximum of six (6) minutes.

All individuals desiring to address the HCRMA must be signed up to do so, prior to the open comment period. For meetings being held by telephonic or videoconference, individuals may contact Maria. E. Alaniz at (956) 402-4762 before 5:00 pm day of the meeting.

The purpose of this comment period is to provide the public an opportunity to address issues or topics that are under the jurisdiction of the HCRMA. For issues or topics which are not otherwise part of the posted agenda for the meeting, HCRMA members may direct staff to investigate the issue or topic further. No action or discussion shall be taken on issues or topics which are not part of the posted agenda for the meeting. Members of the public may be recognized on posted agenda items deemed appropriate by the Chairman as these items are considered, and the same time limitations applies."

Note: Participation by Telephone/Video Conference Call – One or more members of the HCRMA Board of Directors may participate in this meeting through a telephone/video conference call, as authorized by Sec. 370.262, Texas Transportation Code.

This Page
Intentionally
Left Blank

Workshop

Item 1

HIDALGO COUNTY REGIONAL MOBILITY AUTHORITY

AGENDA RECOMMENDATION FORM

BOARD OF DIRECTORS	<u> X </u>	AGENDA ITEM	<u> 1 </u>
PLANNING COMMITTEE	<u> </u>	DATE SUBMITTED	<u> 06/14/24 </u>
FINANCE COMMITTEE	<u> </u>	MEETING DATE	<u> 06/25/24 </u>
TECHNICAL COMMITTEE	<u> </u>		

1. Agenda Item: **WORKSHOP ITEM 1 – PRESENTATION OF HIDALGO COUNTY REGIONAL MOBILITY AUTHORITY BOARD OF DIRECTORS ANNUAL ETHICS AND COMPLIANCE TRAINING**

2. Nature of Request: (Brief Overview) Attachments: X Yes No
 Presentation by Blakely Fernandez, Bracewell Law, on Hidalgo County Regional Mobility Authority Board of Directors Annual Ethics and Compliance Training

3. Policy Implication: Board Policy, Local Government Code, Texas Government Code, Texas Transportation Code, TxDOT Policy

4. Budgeted: Yes No X N/A

5. Staff Recommendation: **Presentation only.**

6. Program Manager’s Recommendation: Approved Disapproved X None

7. Planning Committee’s Recommendation: Approved Disapproved X None

8. Board Attorney’s Recommendation: Approved Disapproved X None

9. Chief Auditor’s Recommendation: Approved Disapproved X None

10. Chief Financial Officer’s Recommendation: Approved Disapproved X None

11. Chief Development Engineer’s Recommendation: Approved Disapproved X None

12. Chief Construction Engineer’s Recommendation: Approved Disapproved X None

13. Executive Director’s Recommendation: Approved Disapproved X None

Hidalgo County Regional Mobility Authority

Annual Ethics & Compliance Training

June 25, 2024



BRACEWELL

INTERNAL ETHICS & COMPLIANCE PROGRAM

RMAAs required to **adopt** and **enforce** an internal ethics and compliance program

- Detect and prevent violations of the law, regulations and ethical standards
- Enforce compliance with program
- Institute monitoring and auditing systems
- Provide periodic training for Board Members and employees

- High level personnel responsible for oversight of compliance
- Care taken to avoid delegation of compliance to irresponsible parties
- Communicate compliance standards to employees
- Periodic ethics training

INTERNAL ETHICS AND COMPLIANCE PROGRAM

ETHICS

- Conduct & behavior
- Public trust
- Avoid the appearance of impropriety

COMPLIANCE

- Evidence
- Enforcement
- Consult Directly with Executive Director or General Counsel

OVERVIEW OF DISCUSSION

7 KEY AREAS

1. Conflict of Interest
2. Bribery & Gifts / Honoraria
3. Use of Government Property
4. Nepotism
5. Open Government
6. Public Information & Records Retention
7. Compliance Requirements

STATE LAW

TXDOT RULES

HCRMA POLICIES

1. Conflict of Interest

1. CONFLICT OF INTEREST

Under State law:

No participation in a vote on a matter involving a **business entity** or **property** in which an official has a **substantial business or property interest** and would receive **economic benefit**

Thresholds are low:

**Substantial Business Interest =
10% voting shares / 10% of total income / \$15,000 in FMV**

**Substantial Property Interest =
value of \$2,500 or more**

Responsibility of Official:

1. Don't vote or deliberate
2. Disclose

Who is an Official?

Authority to vote or make a decision on a proposed agreement

1. CONFLICT OF INTEREST (Directors and Employees)

RMA RULES

- No acceptance or solicitation of any gift, favor or service that **MIGHT** influence official duties
- No employment, business or professional activity that **MIGHT** require/induce the disclosure of RMA's confidential information
- No employment or compensation that **COULD** impair independence of judgement
- No personal investments (including spouse) that **COULD** create a conflict with the RMA
- No solicitation or acceptance of any benefit for the exercise of official duties
- No performance of official duties in favor of another
- No personal interest in RMA agreement

RESPONSIBILITY OF OFFICIAL

- No lunches, dinners, trips that would be **perceived** to influence decisions
- No sharing HCRMA confidential information – information not yet public
- No purchase of land in or near projected ROW
- No interest in RMA contracts

1. CONFLICT OF INTEREST

RMA RULES

CONSEQUENCE FOR CONFLICTS IS INELIGIBILITY FOR SERVICE

- A person is ineligible to serve on the RMA Board or as Executive Director if that person or his spouse:
 - Is employed by or manages an entity or organization (other than a political subdivision) that is regulated or receives funds from TxDOT, the RMA or the County
 - Directly or indirectly owns or controls more than 10% a business entity or other organization that is regulated by or receives funds from TxDOT, the RMA, or the County
 - Uses or receives a substantial amount of tangible goods, services, or funds from TxDOT, the RMA, or the County; or
 - Is required to register as a lobbyist under Government Code, Chapter 305, because of the person's activities for compensation on behalf of a profession related to the operation of TxDOT, the RMA, or the County

Responsibility of the Official

- Disclose potential conflicts
- If a conflict exists, resign from position

1. CONFLICT OF INTEREST

HCRMA Disclosure Requirements

- Board Ethics and Compliance Certificate
 - Annually
- Conflicts Disclosure Statement - Contracting
 - File within 7 days of becoming aware of interest
 - Applies to immediate family
 - Interest includes employment or business relations with an HCRMA vendor resulting in taxable income
 - Triggered by a contract

LOCAL GOVERNMENT OFFICER CONFLICTS DISCLOSURE STATEMENT		FORM CIS
<small>(Instructions for completing and filing this form are provided on the next page.)</small>		OFFICE USE ONLY Date Received
<small>This questionnaire reflects changes made to the law by H.B. 23, 84th Leg., Regular Session. This is the notice to the appropriate local governmental entity that the following local government officer has become aware of facts that require the officer to file this statement in accordance with Chapter 176, Local Government Code.</small>		
1	Name of Local Government Officer	
2	Office Held	
3	Name of vendor described by Sections 176.001(7) and 176.003(a), Local Government Code	
4	Description of the nature and extent of each employment or other business relationship and each family relationship with vendor named in item 3.	
5	List gifts accepted by the local government officer and any family member, if aggregate value of the gifts accepted from vendor named in item 3 exceeds \$100 during the 12-month period described by Section 176.003(a)(2)(B). Date Gift Accepted _____ Description of Gift _____ Date Gift Accepted _____ Description of Gift _____ Date Gift Accepted _____ Description of Gift _____ (attach additional forms as necessary)	
6	AFFIDAVIT I swear under penalty of perjury that the above statement is true and correct. I acknowledge that the disclosure applies to each family member (as defined by Section 176.001(2), Local Government Code) of this local government officer. I also acknowledge that this statement covers the 12-month period described by Section 176.003(a)(2)(B), Local Government Code. _____ Signature of Local Government Officer AFFIX NOTARY STAMP / SEAL ABOVE Sworn to and subscribed before me, by the said _____, this the _____ day of _____, 20 _____, to certify which, witness my hand and seal of office. _____ Signature of officer administering oath Printed name of officer administering oath Title of officer administering oath	

2. Bribery & Gifts

2. BRIBERY & GIFTS

Under State law:

Bribery is intentionally or knowingly soliciting, offering, or accepting a **benefit** in exchange **for a decision, opinion, recommendation, vote, or other exercise of official discretion** (2nd degree felony)

Benefit	Acceptance	Timing	Influence
<ul style="list-style-type: none">• Any financial gain or advantage• Under TxDOT conflict rules, includes working meal	<ul style="list-style-type: none">• In exchange for vote or action• From a party interested in a business opportunity or subject to HCRMA jurisdiction	<ul style="list-style-type: none">• An item accepted <i>after</i> the exercise of official action may still be considered bribery	<ul style="list-style-type: none">• Bribery may occur even if the item was not solicited and had no influence over the decision

Bribery statute applies to “public servants”

A person selected or employed as an officer, employee or agent of the government

2. Bribery & Gifts

Exceptions to the Bribery Statute

with TxDOT clarifications

Non Cash Items	Food, Lodging & Transportation	Gift from a Friend, Relative or Business Associate	Payment for Legitimate Consideration
<ul style="list-style-type: none">• <i>Token item distributed generally as a normal means of advertising and that does not exceed an estimated value of \$25</i>	<ul style="list-style-type: none">• <i>Reimbursement for food, travel, or lodging to an official event</i>• <i>Honorarium in the form of a meal served at an official, transportation-related event, such as a conference</i>	<ul style="list-style-type: none">• <i>[no TxDOT clarification]</i>	<ul style="list-style-type: none">• <i>[no TxDOT clarification]</i>

Note:
State law exceptions are to criminal liability. Consider other applicable rules and appearance of impropriety.

3. Use of Government Property

3. USE OF GOVERNMENT PROPERTY

- Computers and software (including **email systems**, phones, fax and copy machines, and other equipment owned or leased by HCRMA or provided for HCRMA use should be used only for official HCRMA business)
- Lost or stolen property must be reported immediately

Note:

Abuse of Office includes **Misuse of Information**

- Using official information to acquire or assist another acquire a pecuniary interest in any property, transaction, or enterprise.
- Speculating or aiding another to speculate on the basis of official information.
- Disclosing or using the information to obtain a benefit or to harm another.

4. Nepotism

4. NEPOTISM

State Law

- May not appoint or vote for the appointment of an individual to a paid position if the individual is related to the public official within the:
 - 3rd degree of consanguinity (filled circles)
 - 2nd degree of affinity (outlined circles)
- Prohibition applies to all members of the board (unlike conflict of interest where the affected member abstains)

RESPONSIBILITY OF OFFICIAL

- Do not hire a relative as Executive Director

BRACEWELL

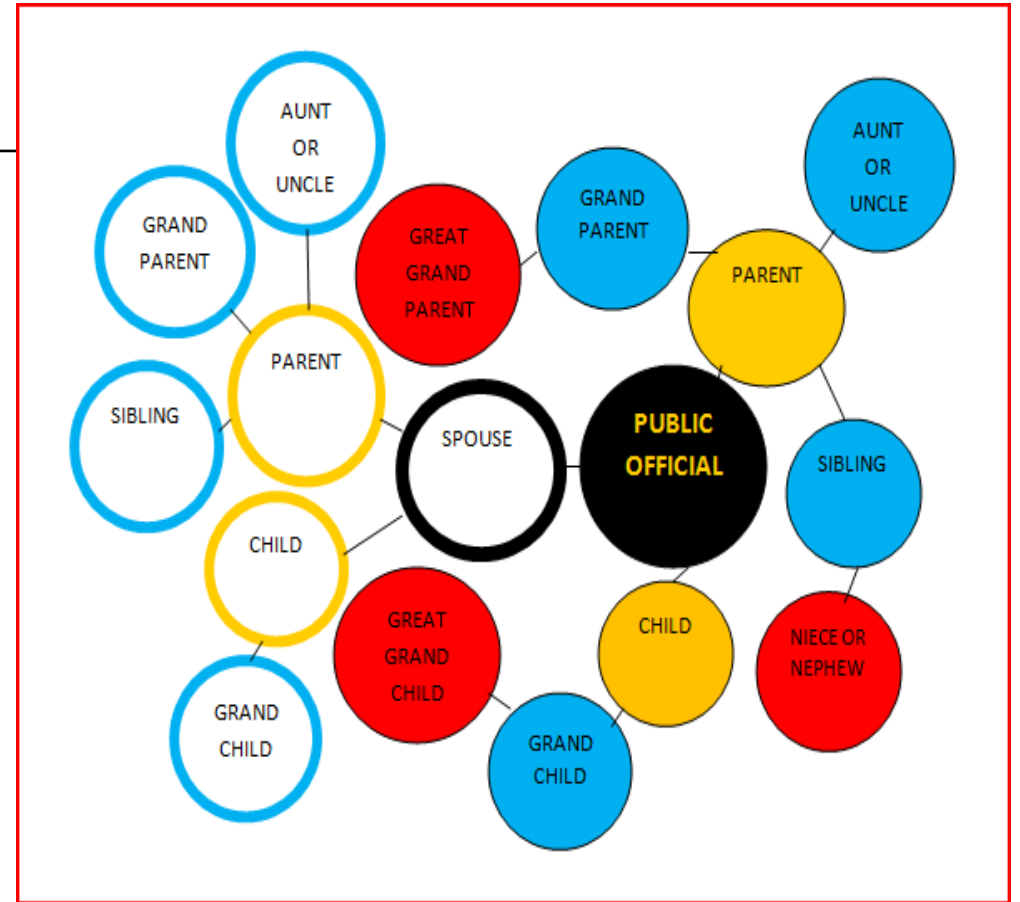

CIRCLES:

- Solid = by blood/consanguinity;
- Open = by marriage/affinity

COLOR:

- Yellow = 1st; Blue = 2nd; Red = 3rd

5. Open Government

Training required for all elected or appointed officials who participate in meetings subject to the Open Records Act.

Training must be completed within 90 days of taking office.

Video Training is available on line and a course certificate can printed upon completion.

TEXAS ATTORNEY GENERAL
**Open Meetings Act
Training**

<https://www.texasattorneygeneral.gov/open-government/governmental-bodies/pia-and-oma-training-resources/open-meetings-act-training>

5. OPEN GOVERNMENT

OPEN MEETINGS ACT

- Applicability of the Act
- Notice Requirements
- How to Conduct Open Meetings
- When Closed Sessions are Permissible
- Conducting Meetings by Teleconference or Video Conference
- Penalties and Remedies under the Act

5. OPEN GOVERNMENT

OPEN MEETINGS

- All meetings of **governmental bodies** are open
 - Unless the law provides an exception (Executive Session)
 - Meetings may be regular, special, or called meetings
 - Open = Accessible to the Public
 - Within the boundaries of Hidalgo County
 - Accessible to individuals with disabilities
 - Provide for public comment
 - Internet broadcasting of meetings
- All meetings **require public notice**
 - Date, time, place, and subject posting
 - Note: Subject requires enough specificity to be actual notice to the public
 - 72 hours notice required
 - Emergency situations require 1 hour notice (notify media directly)
 - **Notice and agenda** provided on website and physically
- Records of meetings must be maintained
- **It is the Board Members' duty to comply with the Open Meetings Act and failure may be a criminal offense**

What if there is a failure to provide proper meeting notice or other violation of the Act?

- **Actions taken are voidable** (any such actions must be ratified at a subsequent meeting)
- Individuals may sue to prevent threatened actions in violation of the Act

5. OPEN GOVERNMENT

Amarillo Case (2023)

- Texas Open Meetings Act requires every regular, special or called meeting to be open to the public
- Certain matters of “special interest to the public” require the agenda to include more detail than a generalized description of a topic
- With regard to debt,
 - Include purpose and amount
 - Include enough detail to make the structure transparent

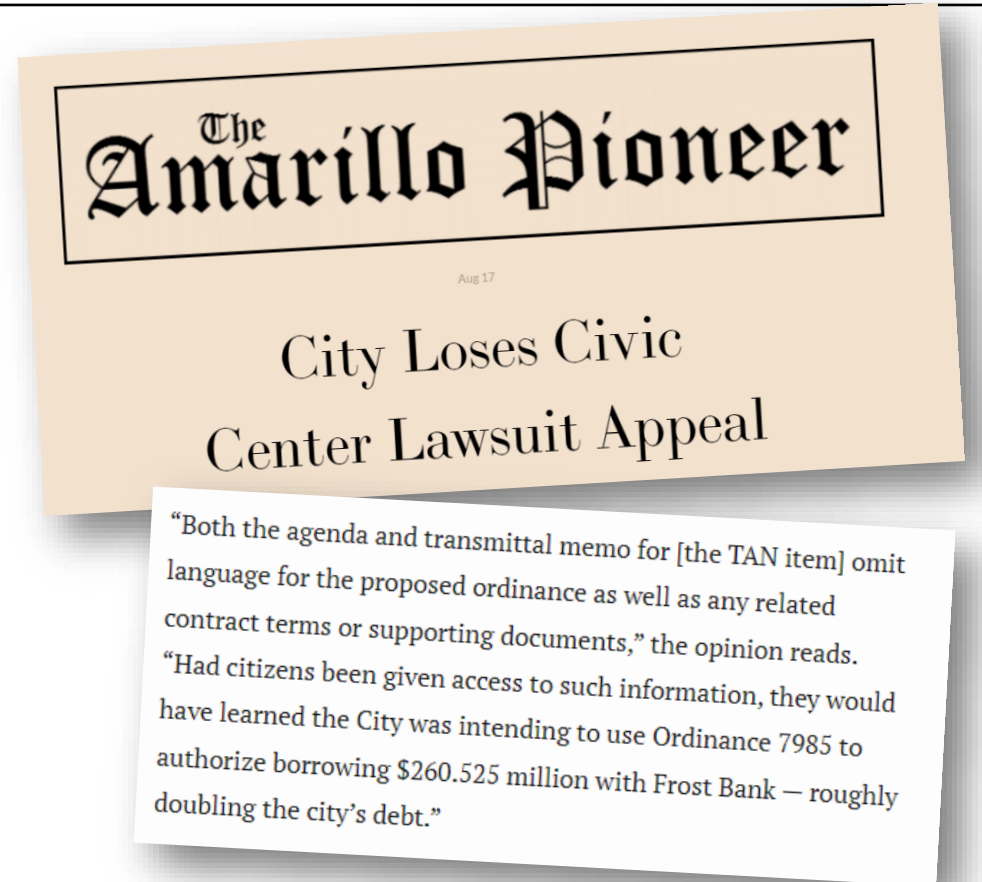

5. OPEN GOVERNMENT

PUBLIC MEETING

- Quorum (4 board members) + Discussion of HCRMA Business
 - Public Hearing
 - County Workshop
 - Emails / Text Messages
 - Walking Quorums
 - Multiple conversations
 - “Polling” Board Members
- Violation = action is voidable
 - In some circumstances, criminal fine and or jail time

NOT A PUBLIC MEETING

- Social Setting / Holiday Event / Dinner
- Convention / Symposium
- Ceremonial event
- Press Conference
- Committee Meetings of less than a quorum (and no final action)
- Candidates Forum or Debate

PROVIDED:

No Discussion of RMA Business
No formal action is taken

5. OPEN GOVERNMENT

WALKING QUORUMS

- Open Meetings Act makes it illegal for members of government body to “**knowingly conspire to circumvent [the Act] by meeting in numbers less than a quorum for purposes of secret deliberations in violation of [the Act].**”

A Board Member commits an offense if he:

- (a) **Knowingly** engages in at least one communication among a series of communications that each occur outside of a meeting and that concern an issue within the jurisdiction of the Authority in which the Members engaging in the individual communications constitute fewer than a quorum of the Members, but the sum of all the Members engaging in the series of communications constitute a quorum of the Members, and
- (b) **Knew at the time** the Member engaged in the communication that the series of communications (i) **involved or would involve a quorum**; and (ii) **would constitute a “deliberation”** once a quorum of members engaged in the series of communications.

Effective September 1, 2019

5. OPEN GOVERNMENT

Exceptions to Open Meetings: Closed Session

Exceptions to the Open Meetings Requirement

- Consultation with attorney
 - Seek advice on legal matters, like pending litigation or settlement matters or contract negotiations, or in compliance with the Texas Disciplinary Rules of Professional Conduct
 - No discussion of non-legal issues
 - No discussion of policy matters
 - No discussion of merits of a contract
- Real Property
 - To deliberate the purchase, exchange, lease, or value of real property if deliberation in an open meeting would have a detrimental effect on the position of the governmental body in negotiations with a third party
- Security Devices
- Personnel
 - To deliberate the appointment, employment, evaluation, reassignment, duties, discipline, or dismissal of a public officer or employee; or
 - To hear a complaint or charge against an officer or employee
- Security Devices or Audits (network security information)

Who attends a Closed Meeting?

- All members of the RMA board are permitted
- Attorney, if attorney consultation is exception
- Board's discretion
 - Officers, employees/consultants if necessary to further discussion
 - NOT arm's length parties
- Do not begin until quorum is present

Must give public notice of Exception

- Post on Agenda
- Identify in the Open Meeting the legal provision authorizing the Closed Session

Must keep a Record

- **Certified Agenda**
 - Record of presiding officer announcing date and time at both beginning and end of Closed Meeting
 - Includes subjects of all deliberations
 - Certification that the agenda is a true correct record of the Closed meeting
 - Confidential document that must be retained for 2 years
- If closed for Attorney Client Privilege, attorney maintains meeting notes.

FINAL ACTION must take place in an open meeting

5. OPEN GOVERNMENT

Responsibility of Official

- It is misdemeanor offense to:
 - Knowingly conspire to circumvent the Act by deliberately meeting with less than a quorum for the purpose of a secret meeting;
 - Participate in a closed session knowing there is no agenda of topics or record taken of the meeting;
 - Knowingly make public the certified agenda or recording of a closed meeting

LUFKIN, Texas (KTRE) - A former Angelina County Judge has been found guilty of violating the open meetings act following his trial.

Don Lymbery, the former Angelina County Judge, was indicted in March 2022 along with two other county authorities in connection with violating the open meeting act. The charge stems from an Aug. 9, 2021, **meeting of the three men in Lymbery's office**. Lymbery denied any wrongdoing, claiming the conversation between the three did not include county business and added that he had to leave his office for an interview shortly after the two commissioners joined him.

On Tuesday, Lymbery was found guilty of the charge by Judge Travis Kitchens in a bench trial, and was sentenced to 35 days in the Angelina County jail and a \$350 fine. The jail time and fine were suspended and Lymbery was placed on 90 days probation and required to report monthly and do 35 hours of community service restitution, according to DA Janet Cassels.

Lymbery was acquitted of his 21 other indictments involving class C charges for allegedly participating in executive sessions knowing that a certified agenda or recording was not being kept.

6. Public information

Training Required for:

- Board Member of a Governmental Body
- The Officer for Public Information of a Governmental Body

Training must be completed with 90 days of taking office.

TEXAS ATTORNEY GENERAL

Public Information Act Training

<https://www.texasattorneygeneral.gov/open-government/governmental-bodies/pia-and-oma-training-resources/public-information-act-training>

6. PUBLIC INFORMATION

- Public Information
 - Information collected, assembled, maintained by or for the HCRMA (any format; any device)
 - Information on HCRMA business belongs to the HCRMA, regardless of whether it's on a personal device
 - Certain exceptions apply
 - Agency Memoranda
 - Drafts
 - Attorney Client Communication
 - Real Estate
 - Third Party Proprietary Information
 - Security / Technology / Network Information

The PIA does not distinguish between personal or government issued devices, rather, focuses on the nature of the communication or document.

6. PUBLIC INFORMATION

Suspension during Catastrophe

- Fire, flood, earthquake, hurricane, tornado, or wind, rain, or snow storm
- Power failure, transportation failure, or interruption of communication facilities
- Epidemic
- Riot, civil disturbance, enemy attack, or other actual or threatened act of lawlessness or violence

NOT a period when staff is required to work remotely

RULES

- One suspension per catastrophe
- 14 days total
- Must notify the Attorney General
- Must provide posted public notice

2023 Legislation

- Greater flexibility in calculating days around holidays
- Provision for “non-business days”
- Government Entities may establish yearly “time limits” per requestor to avoid abuse

6. PUBLIC INFORMATION

TEMPORARY CUSTODIAN RESPONSIBILITY

- Any employee who, in the transaction of official business, creates or receives public information
 - Public information maintained on a personal device must be forwarded to the HCRMA's server for preservation

6. PUBLIC INFORMATION

Director's Responsibility

- Complete Open Records Training
- Avoid using personal devices and email accounts when conducting HCRMA business
- Forward communications received on a personal account to HCRMA server
- Assume any communication regarding the HCRMA is public
- Notify HCRMA staff immediately of requests for public information
- Do not delete or destroy records
 - Pending PIA request
 - Litigation hold

7. Compliance program

7. COMPLIANCE PROGRAM

INTERNAL ETHICS & COMPLIANCE PROGRAM

RMAs required to **adopt** and **enforce** an internal ethics and compliance program

- High level personnel responsible for oversight of program
- Avoid delegation of substantial discretionary authority to individuals who have a propensity to engage in illegal activities
- Effectively communicate to employees and governing board, including periodic training
- Effectively communicate with entity's agents

7. COMPLIANCE PROGRAM

REASONABLE STEPS TO ACHIEVE COMPLIANCE WITH STANDARDS AND PROCEDURES:

- Using monitoring and auditing systems designed to reasonably detect noncompliance
- Providing and publicizing a systems for the HCRMA's employees and agents to report suspected non-compliance without retaliation

CONSISTENT ENFORCEMENT OF COMPLIANCE STANDARDS AND PROCEDURES

EFFORTS TO RESPOND APPROPRIATELY TO DETECTED AND PREVENT OFFENSES

A suspected violation of HCRMA policies, a violation of law, or a breach of fiduciary duty must be immediately reported to the Executive Director or Chairman

Anonymous website reporting:

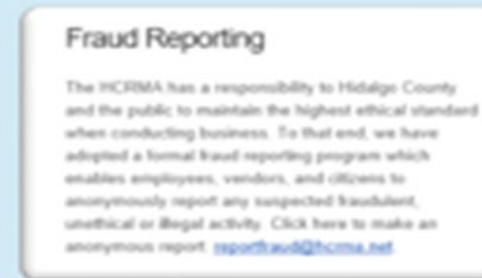

7. COMPLIANCE PROGRAM

Written Code of Conduct to Address:

- Record retention
- Fraud
- Equal Opportunity Employment
- Sexual Harassment and Sexual Misconduct
- Conflicts of Interest
- Personal use of HCRMA property
- Gifts and Honoraria

7. Compliance Program

HCRMA Annual Certifications to TxDOT

- Ethics and Compliance Program adopted
 - Program is designed to detect and prevent violations of law, regulations, and ethic standards
 - HCRMA enforces compliance
- Program satisfies these requirements:
 - Written manual and employee code of conduct
 - Record retention, fraud, equal opportunity employment, sexual harassment and sexual misconduct, conflicts of interest, personal use of HCRMA property, and gifts and honoraria.
 - High-level personnel are responsible for oversight
 - Compliance standards are communicated to employees and board
 - Compliance standards are communicated to HCRMA's agents
 - Compliance standards are achieved through
 - Monitoring and auditing systems to detect noncompliance
 - Providing and publicizing a mechanism for reporting without fear of retaliation
 - Consistent enforcement through appropriate disciplinary mechanisms
 - Reasonable measures to respond to offenses and prevent future offenses

7. COMPLIANCE PROGRAM

Training Evidence:

- Open Meetings Training Certificates
- Public Information Act Training Certificates
- **HCRMA Compliance Certificates**
- Public Investment Act Training Certificates
- Staff Project / Billing Training Evidence

Reports:

- Strategic Plan
- Annual Report
- Financial Reports/Audit
- Investment Reports
- Project Reports
- Toll Entity Financial Report
- Notice of Debt
- Compliance Report
- Disclosure / Gift / Interests
- Post-Issue Compliance Records
- Comptroller Tax / Fee / Debt Report
- Board: Annual Personal Financial Statement

ETHICS AND COMPLIANCE HANDBOOK

ELECTRONIC ETHICS & COMPLIANCE HANDBOOK

Section A.	Law Governing Regional Mobility Authorities
1.	Chapter 370, Texas Transportation Code
2.	Title 43, Chapter 26, Texas Administrative Code
Section B.	Conflict of Interest
1.	Texas Municipal League Conflict of Interest/Disclosure Laws Applicable to City Officials, Employees and Vendors (2017)
2.	See above, Title 43, Chapter 26, Rule 26.51 (Section A-2)
Section C.	Open Government
1.	Texas Attorney General Handbook – Open Meetings (2024)
2.	Texas Attorney General Handbook – Public Information Act (2024)
Section D.	Ethics for Officials
1.	Texas Ethics Commission Guide to Ethics Laws for State Officers and Employees (2022)
Section E.	HCRMA Operations
1.	Bylaws
2.	Current Strategic Plan
3.	Current Budget (2024)
4.	2023 Audit
5.	TxDOT Audit Results – Prior Years
6.	Travel and Reimbursement Policy
7.	Ethics and Compliance Manual (2020)
8.	Ethics and Compliance Training Presentation (2024)
9.	Board Certificate (2024)
Section F.	TxDOT Employee Conduct Handbook - Example
	TxDOT Employee Conduct Handbook

This Page
Intentionally
Left Blank

Item 1A

HIDALGO COUNTY REGIONAL MOBILITY AUTHORITY

AGENDA RECOMMENDATION FORM

BOARD OF DIRECTORS
PLANNING COMMITTEE
FINANCE COMMITTEE
TECHNICAL COMMITTEE

 X

AGENDA ITEM
DATE SUBMITTED
MEETING DATE

 1A
06/19/2024
06/25/2024

1. Agenda Item: **REPORT ON PROGRAM MANAGER ACTIVITY FOR 365 TOLLWAY PROJECT AND HIDALGO COUNTY LOOP**
2. Nature of Request: (Brief Overview) Attachments: X Yes No
Report on 365 Tollway and Hidalgo County Loop
3. Policy Implication: Board Policy, Local Government Code, Texas Government Code, Texas Transportation Code, TxDOT Policy
4. Budgeted: Yes No X N/A
5. Staff Recommendation: **Report only.**
6. Program Manager's Recommendation: Approved Disapproved X None
7. Planning Committee's Recommendation: Approved Disapproved X None
8. Board Attorney's Recommendation: Approved Disapproved X None
9. Chief Auditor's Recommendation: Approved Disapproved X None
10. Chief Financial Officer's Recommendation: Approved Disapproved X None
11. Chief Development Engineer's Recommendation: Approved Disapproved None
12. Chief Construction Engineer's Recommendation: X Approved Disapproved None
13. Executive Director's Recommendation: X Approved Disapproved None

HCRMA Board of Directors

S. David Deanda, Jr., Chairman
Ezequiel Reyna, Jr., Vice-Chairman
Juan Carlos Del Angel, Secretary/Treasurer
Gabriel Kamel, Director
Francisco "Frank" Pardo, Director
Sergio Saenz, Director
Michael J. Williamson, Director

HCRMA Administrative Staff

Pilar Rodriguez, PE, Executive Director
Ramon Navarro IV, PE, CFM, Chief Constr. Eng.
Celia Gaona, CIA, Chief Auditor/Compliance Ofcr.
Jose Castillo, Chief Financial Ofcr.

General Engineering Consultant
HDR ENGINEERING, INC.

Overview

- ❑ 365 TOLL Project Overview
 - + Granjeno Wetland Mitigation Project
- ❑ Section C
- ❑ Overweight Permit Summary

MISSION STATEMENT:

To provide our customers with a rapid and reliable alternative for the safe and efficient movement of people, goods, and services.



HCRMA STRATEGIC PLAN

DEVELOP THE
INFRASTRUCTURE TO
SERVE A POPULATION
OF APPROXIMATELY
800,000 RESIDENTS
AND
5 INTERNATIONAL
PORTS OF ENTRY

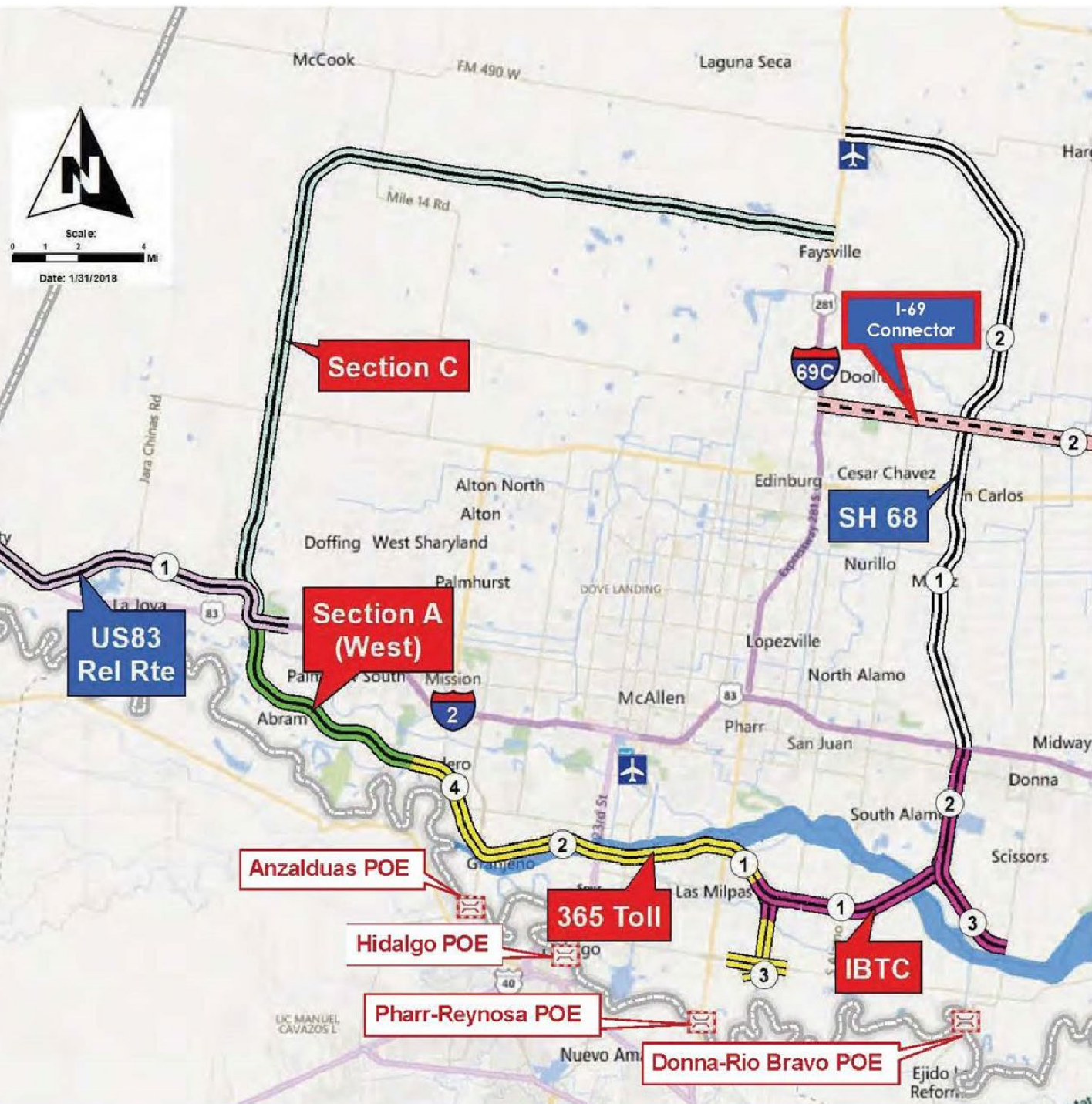

- Project**
-  0010 IBTC
 -  0030 365 TOLL
 -  0040 Section A West
 -  0050 US 83 Relief Route
 -  0060 Section C
 -  0070 SH 68
 - FM1925 SH 68 to US 77**
 -  PH1 FM 491 to US 77
 -  PH2 SH 68 to FM 491

SCALE: 1 inch = 4 miles



AUTHOR: Eric Davila, PE, PMP, CFM
DATE: 4/10/2019

2019-2023 Strategic Priorities

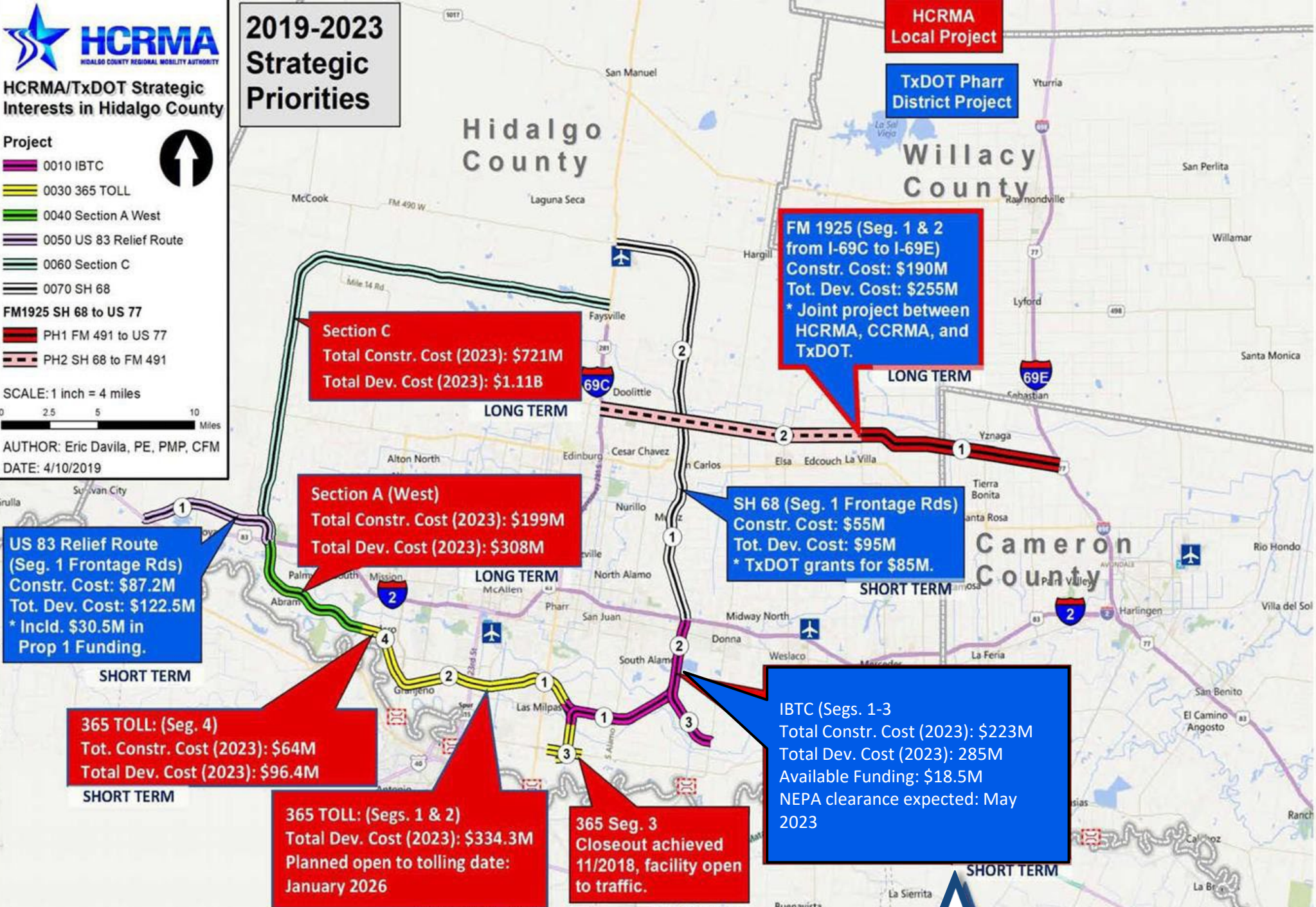

SECTION C Discussions

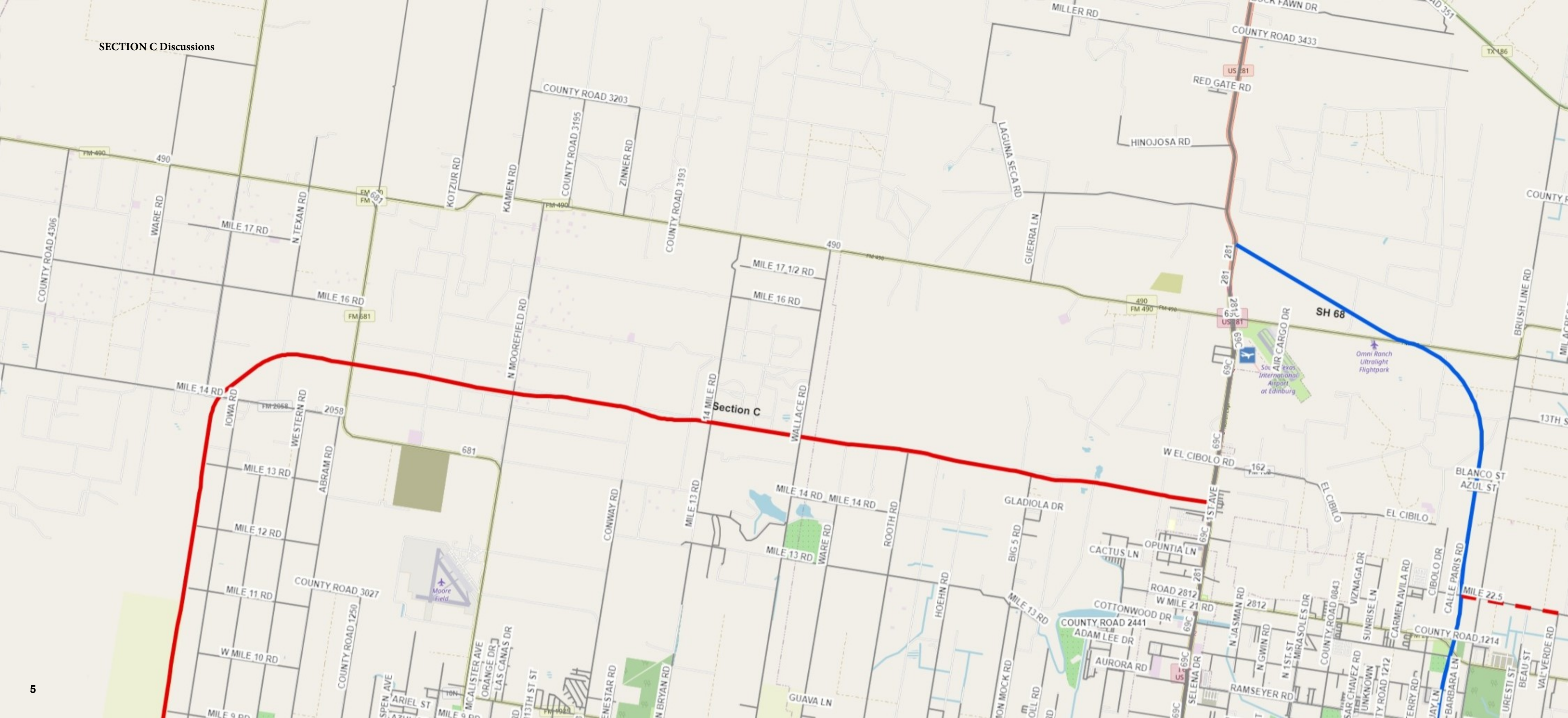

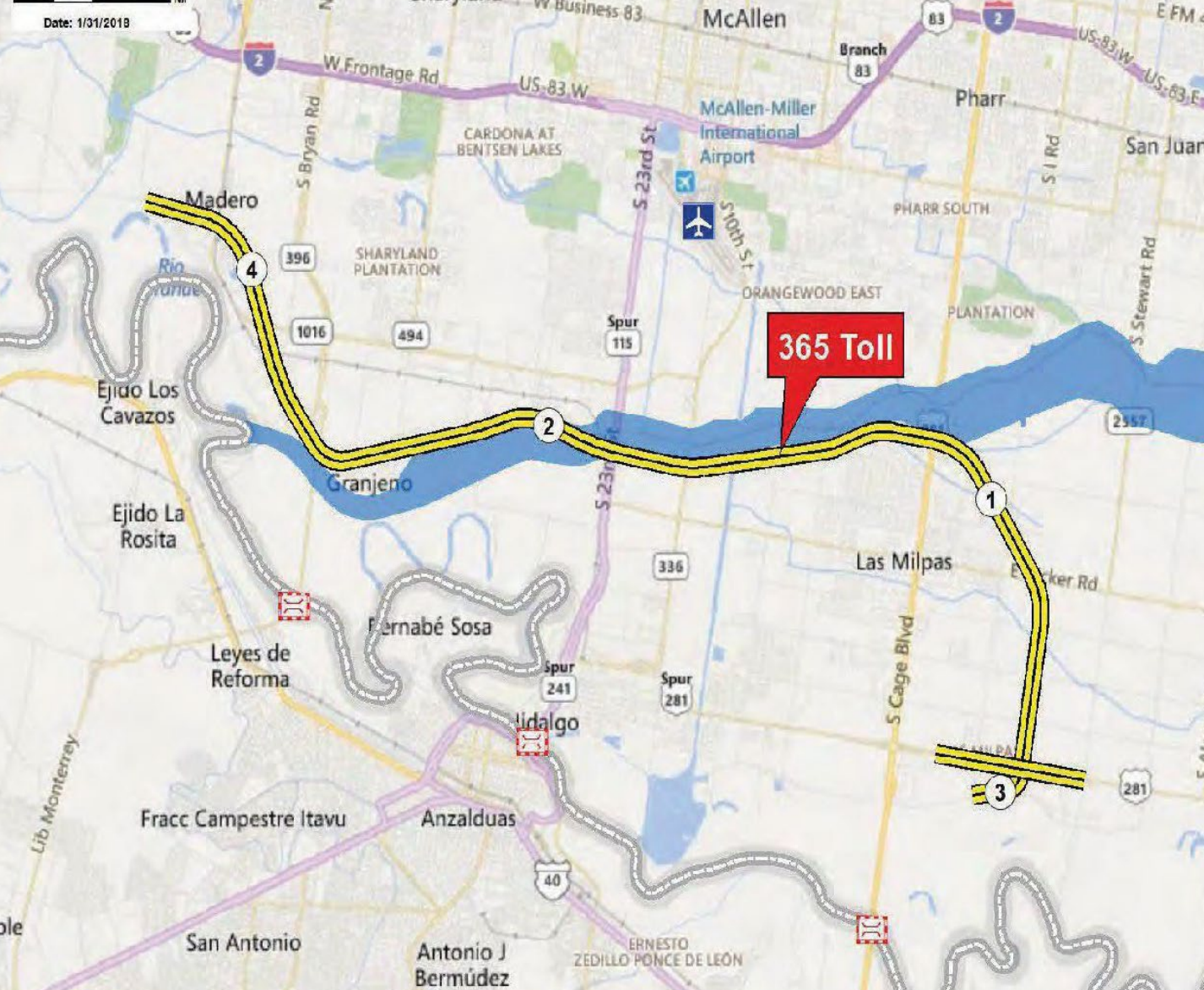

MAJOR MILESTONES:
 NEPA CLEARANCE
 07/03/2015

100% ROW ACQUIRED

PH 1: 365 SEG. 3
 LET: 08/2015
COMPLETED

PH 2: 365 TOLL
SEGS. 1 & 2
LET: 11/2021
 OPEN: 01/2026

[SEGS. 1 & 2] LIMITS FROM 0.8 MI. W. FM 396 / ANZ. HWY.
 TO US 281 / BSIF CONNECTOR [365 SEG. 3 COMPLETED]
 [SEG. 4 FUTURE] LIMITS FROM FM 16 / CONWAY
 TO 0.8 MI. W. FM 396 / ANZALDUAS HIGHWAY



GRANJENO WETLAND MITIGATION SITE

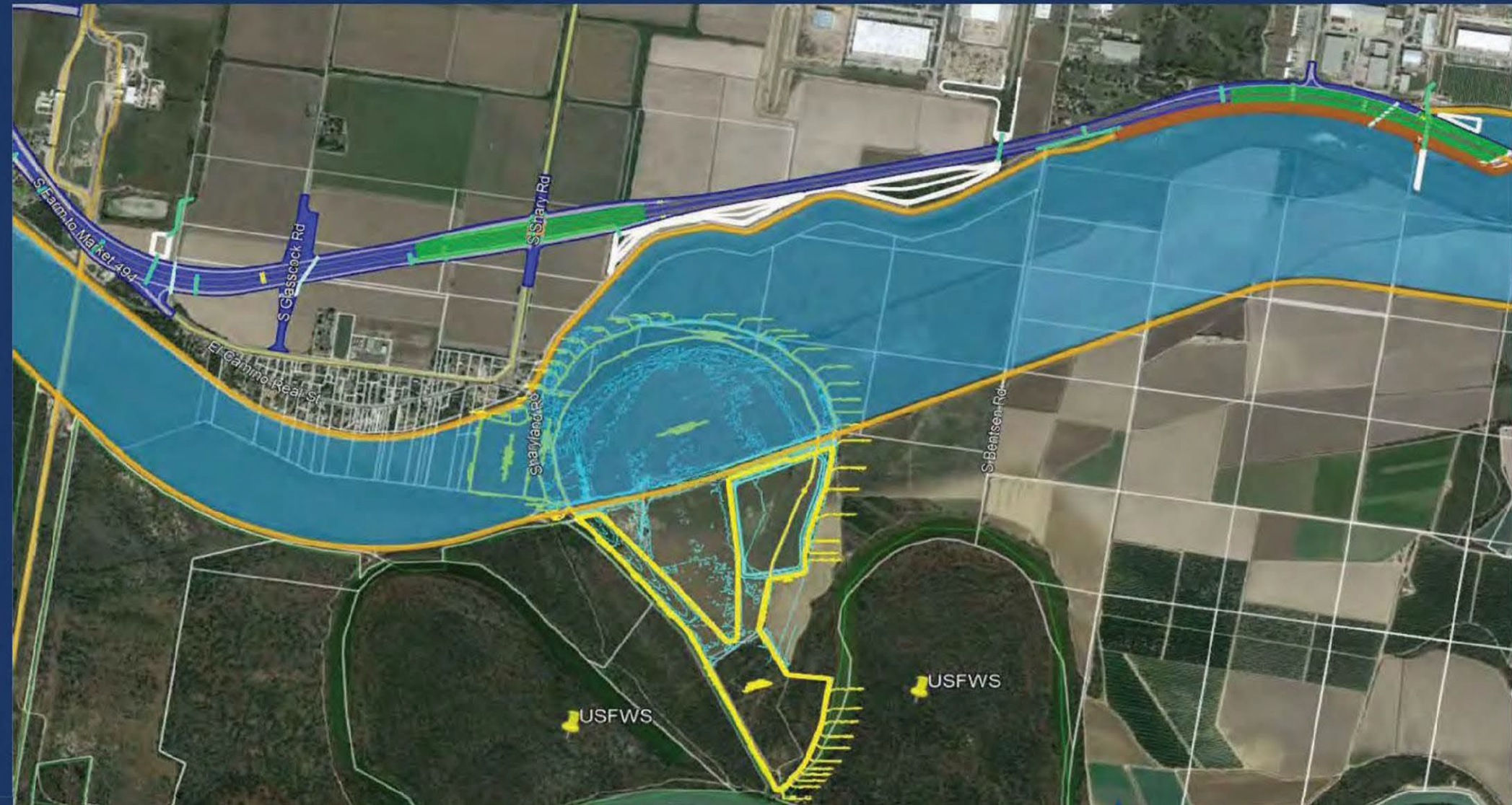

LETTING:

PROJECT DETAILS:

The HCRMA Granjeno Wetland Mitigation Site project is for the restoration of 23.88 acres of land, including approximately 17 acres planned specifically for wetland restoration. The project consists of grading and compaction of approximately 19 acres to establish a wetland which includes the placement of a clay liner and plant root zone soil strata. It also includes berm grading and compaction of approximately 6 acres of upland area. The project includes construction of an access driveway and road including maintenance and brush clearing/trimming. The project includes construction of a groundwater well with controls, approximately 3,000 linear feet of pvc distribution pipe, associated equipment, and a security fence.

- (MANDATORY) In-person or Virtual Attendance Option.

Pre-Bid Meeting: Tuesday, February 20, 2024, 2 P.M. C.S.T.

- All inquiries submitted by 3:00PM CST on Friday, March 8, 2024. Inquiries beyond this date were not responded to.

Electronic bids via CivCast received until 3:00 P.M. C.S.T., Wednesday, March 13, 2024.

Bid opening date & time: Wednesday, March 13, 2024, Opening 3:05 P.M. C.S.T.

3.26.24 Sole bid: MitRes Services, LLC , Board directive to implement cost saving measures

HCRMA \ HDR discussions on options and efficiencies to bring project back within budget

4.18.24 HCRMA awarded to the lowest, responsive and responsible bidder MitRes Services, LLC. for construction of the Project.





Memo

Date: Tuesday, June 11, 2024

Project: Granjeno Wetland Mitigation Site Project

To: Norma Garza, PE

CC: Pilar Rodriguez, Ramon Navarro, Dan Paredes, Blakely Fernandez

From: Samuel Saldivar

Subject: Recommendation to Continue Award of Construction Contract

The HCRMA, legal counsel, and HDR are in receipt TxDOT's response to the recommendation to award the Granjeno Wetland Mitigation Site project (Bid No. 2024-004) to MiteRes Services, LLC. This memo provides a response to the following comments/questions.

- Is MitRes Services, LLC a TxDOT prequalified bidder?
 - Response: The HCRMA and HDR stipulated in the bidding documents that TxDOT precertification was required. While this was preferred, there was concern that there were no TxDOT prequalified bidders with the experience or interest to deliver they type of site work. During the first bidding of this project, Bid No. 2023-001, only two bidders engaged the HCRMA with questions and bids. Neither were TxDOT prequalified, but they displayed examples of the work experience needed to the deliver this project. A bidder question was received asking about the TxDOT prequalification requirement. I recommended to the HCRMA that the requirement be waived to move forward with bidding and construction. To avoid losing additional time to construct this project, I recommended the same waiver be accommodated with the Re-Bid (Bid No. 2024-001) to avoid a no-bids-received scenario to the bidding advertisement. It is imperative that the Contractor has a strong experience with civil site environmental mitigation, and TxDOT prequalification is a bid formality that does not help in that regard.
- Bid appears to be mathematically unbalanced.
 - Response: Remote site work with a scope of work that focuses on soil management, planting, and groundwater well installation is an uncommon project type. The bid items which represent 14% or more of the total bid price which exceeded the Engineer's Unti Price indicate where the Contractor has assigned the most effort and risk. It is reasonable to see higher prices for these items.



I recommend the HCRMA move forward with awarding the contract to MitRes Services, LLC for the following reasons:

- MitRes Services, LLC has well over 10 years of experience with environmental restoration projects. They have delivered large-scale infrastructure projects, including restoration of 359,000 linear feet of streams and over 1,500 acres of wetlands.
- HCRMA and HDR have bid this project twice. We will lose time if we have to bid this project a third time. We are nearing the end of the procurement window to secure the plant species type required for the project. If the project is rebid, the third bidding will need to be delayed until the first quarter of 2025.
- Delaying the project another year will subject the project to increased cost due to yearly and market drive cost increases. The project has already seen at least a 38% increase since preparing for bid advertisement.
- The project is not utilizing state or federal funds. The funding of this project is through local revenue; therefore, it is a non-participating project.

Samuel Saldivar, Jr., PE

Thursday, September 14, 2023

Lenguaje ▼

Specialized Overweight Permits

Hidalgo County allows shippers to securely order specialized overweight permits online. The permits cover travel over the Hidalgo County roads listed below for vehicles weighing no more than the Mexican Legal Weight Limit or 125,000 lbs. For a more detailed explanation, see below.

Permit Information

The Hidalgo County Regional Mobility Authority (HCRMA) administers the overweight permit corridor system for the Hidalgo County. Overweight permits issued through the HCRMA are only valid for destinations originating from the following points of entry:

- Anzalduas Bridge
- Pharr-Reynosa Bridge
- Donna-Rio Bravo Bridge
- Progreso Bridge

Or for movement on the following roads:

- (1) U.S. Highway 281 between its intersection with Pharr-Reynosa International Bridge and its intersection with State Highway 336.
- (2) State Highway 336 between its intersection with U.S. Highway 281 and its intersection with Farm-to-Market Road 1016.
- (3) Farm-to-Market Road 1016 between its intersection with State Highway 336 and its intersection with Trinity Road.
- (4) Trinity Road between its intersection with Farm-to-Market Road 1016 and its intersection with Farm-to-Market Road 396.
- (5) Farm-to-Market Road 396 between its intersection with Trinity Road and its intersection with the Anzalduas International Bridge.
- (6) Farm-to-Market Road 2061 between its intersection with Farm-to-Market Road 3072 and its intersection with U.S. Highway 281.
- (7) U.S. Highway 281 between its intersection with the Pharr-Reynosa International Bridge and its intersection with Spur 29.
- (8) Spur 29 between its intersection with U.S. Highway 281 and its intersection with Doffin Canal Road.
- (9) Doffin Canal Road between its intersection with the Pharr-Reynosa International Bridge and its intersection with Spur 29.
- (10) FM 2557 (Stewart Road) from US 281/Military Highway to Interstate 2 (US 83).
- (11) FM 3072 (Dicker Road) from Veterans Boulevard ('I' Road) to Cesar Chavez Road.
- (12) Route 12: US 281 (Cage Boulevard) from US 281/Military Highway to Anaya Road.
- (13) US 281/Military Highway from Spur 29 to FM 1015.
- (14) Farm to Market 1015 - Progreso International Bridge to Mile 9 North.
- (15) US 83 Business - Farm to Market 1015 to South Bridge Avenue.

The gross weight of cargo and equipment shall not exceed the allowable permissible axle load, the Mexican Legal Weight Limit or 125,000 lbs, whichever is less, and the dimensions of the load and vehicle shall not exceed 12' wide, 15'6" high, or 110' long.

OVERWEIGHT / OVERSIZE CORRIDOR SEGMENTS

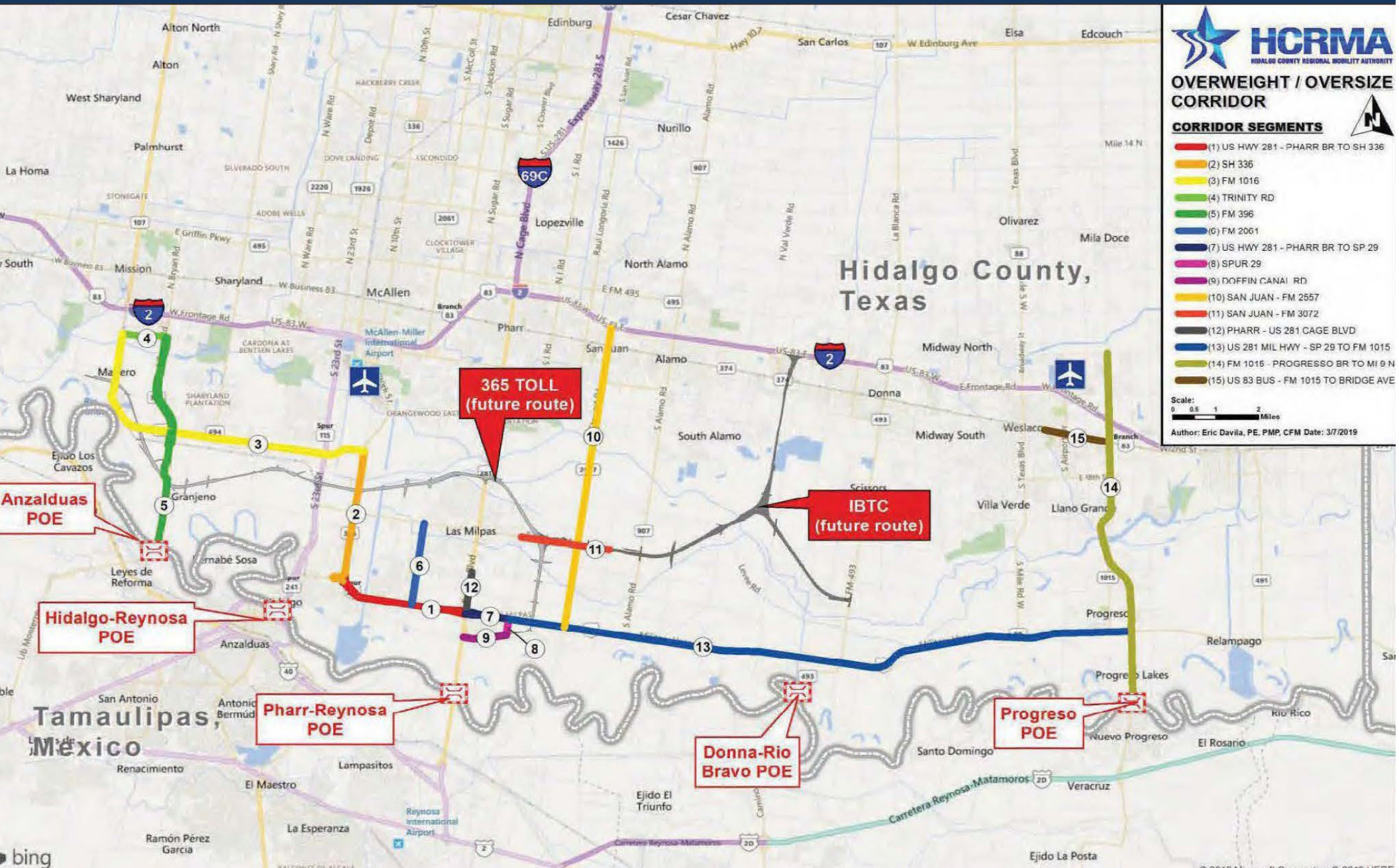

OVERWEIGHT / OVERSIZE CORRIDOR

CORRIDOR SEGMENTS

- (1) US HWY 281 - PHARR BR TO SH 336
- (2) SH 336
- (3) FM 1016
- (4) TRINITY RD
- (5) FM 396
- (6) FM 2061
- (7) US HWY 281 - PHARR BR TO SP 29
- (8) SPUR 29
- (9) DOFFIN CANAL RD
- (10) SAN JUAN - FM 2557
- (11) SAN JUAN - FM 3072
- (12) PHARR - US 281 CAGE BLVD
- (13) US 281 MIL HWY - SP 29 TO FM 1015
- (14) FM 1015 - PROGRESSO BR TO MI 9 N
- (15) US 83 BUS - FM 1015 TO BRIDGE AVE

Scale: 0 0.5 1 2 Miles
 Author: Eric Davila, PE, PMP, CFM Date: 3/7/2019

▶ ACCUMULATED OVERWEIGHT REPORT:

January 14, 2014 - May 31, 2024

Total Permits Issued:	348,526
Total Amount Collected:	\$ 61,755,746
■ Convenience Fees:	\$ 1,214,346
■ Total Permit Fees:	\$ 60, 541,400
-Pro Miles:	\$ 1,045,578
-TxDOT:	\$ 51,460,190
-HCRMA	\$ 8,035,632

*Effective November 13, 2017, permit fee increased from \$80 to \$200



▶ OVERWEIGHT REPORT FOR 2024:

January 1, 2024 - May 31, 2024

Total Permits Issued:	33,819
Total Amount Collected:	\$ 6,911,184
■ Convenience Fees:	\$ 147,384
■ Total Permit Fees:	\$ 6,763,800
-Pro Miles:	\$ 101,457
-TxDOT:	\$ 5,749,230
-HCRMA	\$ 913,113

JANUARY 1, 2024 – May 31, 2024

Overweight/Oversized Permit Count
2022 - 2024 Monthly Comparison

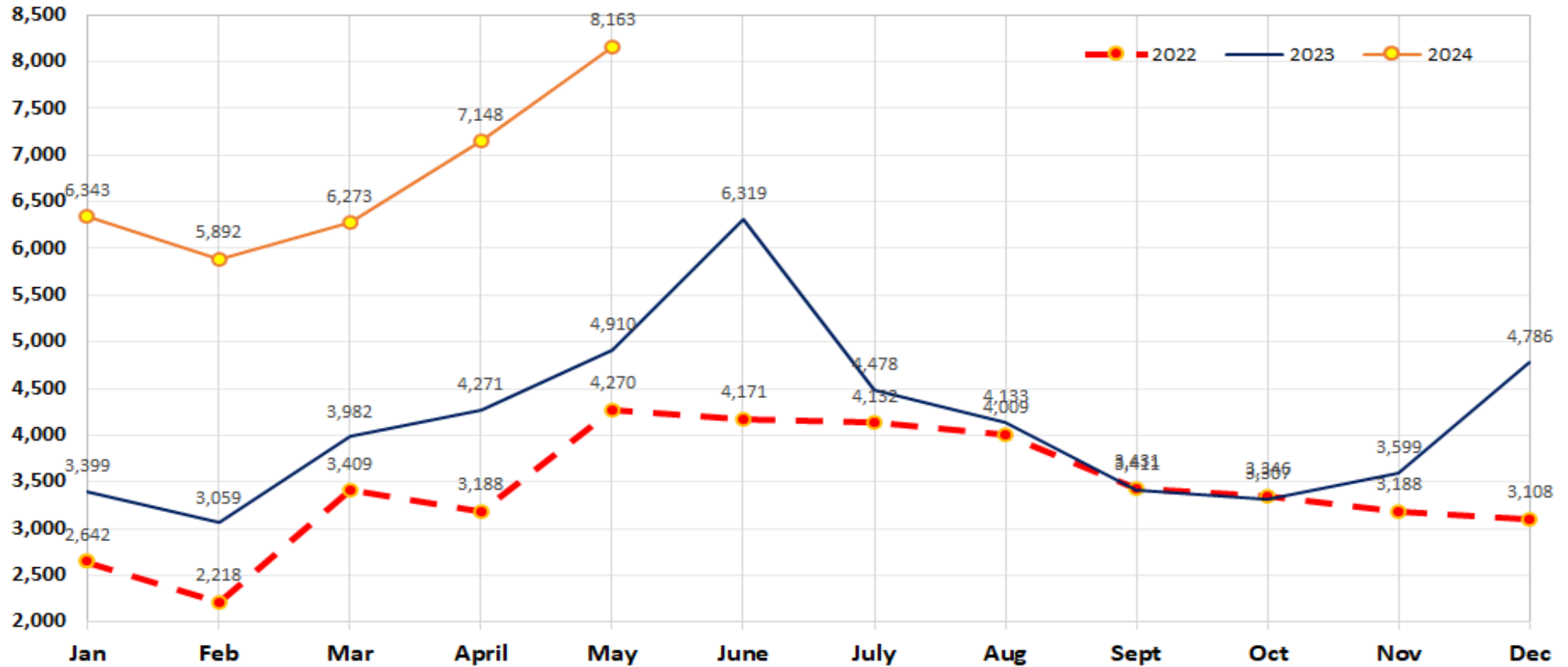

NOTES:

1. The annual accumulated permit count for 2022: 15,727 2023: 19,621 2024: 33,819

Annual increase comparison of: 2022: 18,092 [115%] and 2023:14,198[72.4%]

2. Monthly permit count of 8,163 represents a 66.3% (increase, 3,253) compared to the same month in 2023 (4,910).

This Page
Intentionally
Left Blank

Item 1B

HIDALGO COUNTY REGIONAL MOBILITY AUTHORITY

AGENDA RECOMMENDATION FORM

BOARD OF DIRECTORS	<u> X </u>	WORKSHOP ITEM	<u> 1B </u>
PLANNING COMMITTEE	<u> </u>	DATE SUBMITTED	<u> 06/18/2024 </u>
FINANCE COMMITTEE	<u> </u>	MEETING DATE	<u> 06/25/2024 </u>
TECHNICAL COMMITTEE	<u> </u>		

1. Agenda Item: **REPORT ON CONSTRUCTION ACTIVITY FOR THE 365 TOLLWAY PROJECT.**

2. Nature of Request: (Brief Overview) Attachments: X Yes No
Report on 365 Tollway Project Construction Activities.

3. Policy Implication: Board Policy, Local Government Code, Texas Government Code, Texas Transportation Code, TxDOT Policy

4. Budgeted: Yes No X N/A

5. Staff Recommendation: **Report only.**

6. Program Manager's Recommendation: Approved Disapproved X None

7. Planning Committee's Recommendation: Approved Disapproved X None

8. Board Attorney's Recommendation: Approved Disapproved X None

9. Chief Auditor's Recommendation: Approved Disapproved X None

10. Chief Financial Officer's Recommendation: Approved Disapproved X None

11. Chief Development Engineer's Recommendation: Approved Disapproved X None

12. Chief Construction Engineer's Recommendation: X Approved Disapproved None

13. Executive Director's Recommendation: Approved Disapproved X None

HCRMA Board of Directors

S. David Deanda, Jr., Chairman

Ezequiel Reyna, Jr., Vice-Chairman

Juan Carlos Del Angel, Secretary/Treasurer

Gabriel Kamel, Director

Sergio Saenz, Director

Francisco “Frank” Pardo, Director

Michael J. Williamson, Director

HCRMA Administrative Staff

Pilar Rodriguez, PE, Executive Director

Ramon Navarro IV, PE, CFM, Chief Constr. Eng.

Celia Gaona, CIA, Chief Auditor/Compliance Ofcr.

Jose Castillo, Chief Financial Ofcr.

General Engineering Consultant

HDR Engineering, Inc.

HCRMA STRATEGIC PLAN

DEVELOP THE
INFRASTRUCTURE TO
SERVE A POPULATION
OF APPROXIMATELY
800,000 RESIDENTS
AND
5 INTERNATIONAL
PORTS OF ENTRY

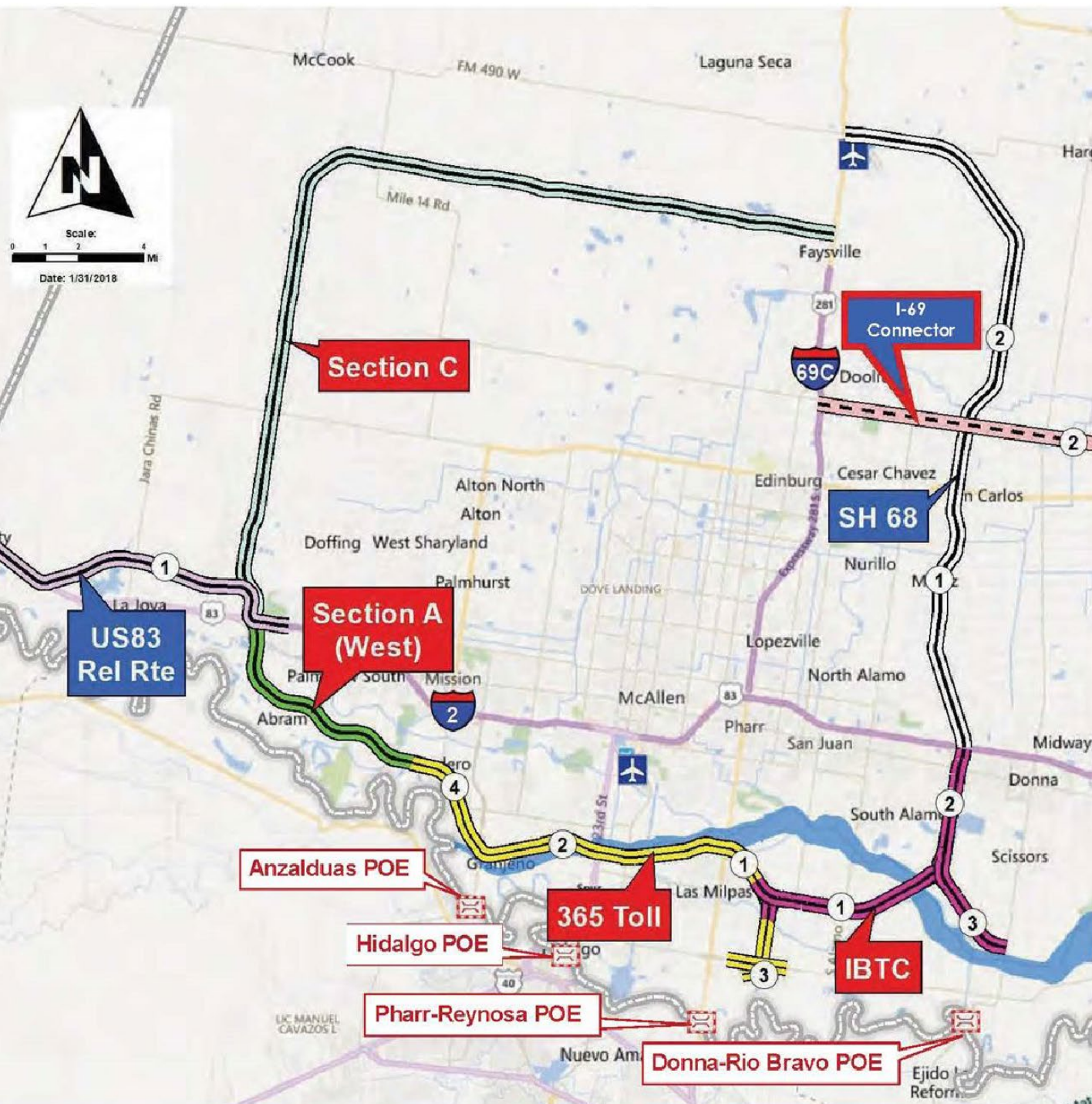

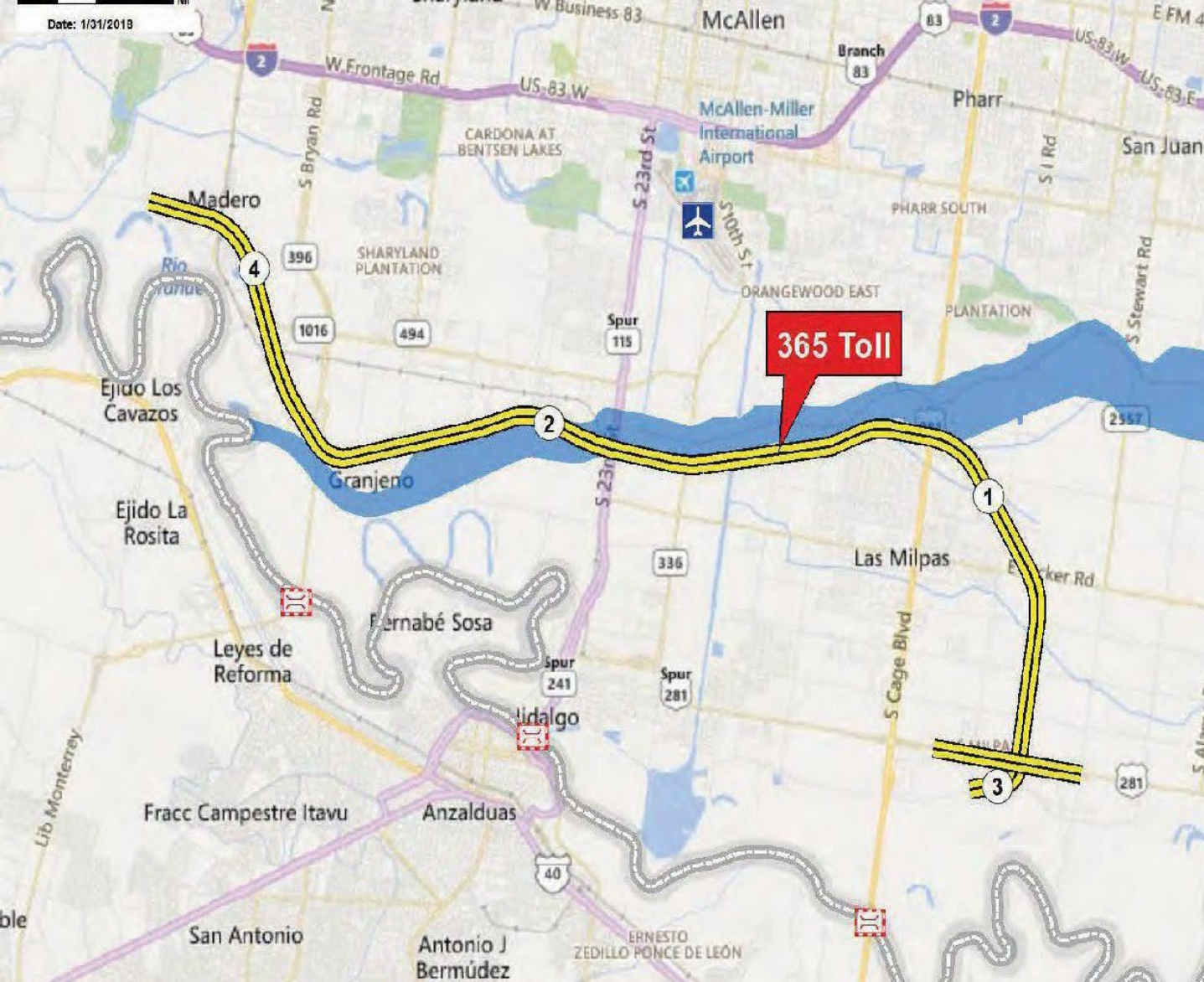

MAJOR MILESTONES:
 NEPA CLEARANCE
 07/03/2015

100% ROW ACQUIRED

PH 1: 365 SEG. 3

LET: 08/2015

COMPLETED

PH 2: 365 TOLL

SEGS. 1 & 2

LET: 11/2021

OPEN: 01/2026

[SEGS. 1 & 2] LIMITS FROM 0.8 MI. W. FM 396 / ANZ. HWY.
 TO US 281 / BSIF CONNECTOR [365 SEG. 3 COMPLETED]
 [SEG. 4 FUTURE] LIMITS FROM FM 16 / CONWAY
 TO 0.8 MI. W. FM 396 / ANZALDUAS HIGHWAY





**STATEMENTS OF QUALIFICATION
FOR
CONSTRUCTION MATERIALS TESTING
LABORATORY SERVICES
AND
FORENSIC INVESTIGATION AND EVALUATION OF
IN-PLACE CONSTRUCTION MATERIALS
365 TOLLWAY PROJECT**

“SOQ – CMT LAB AND FORENSIC SERVICES – 2024-05”.



Bid Results

[Download Bid Folders](#)

Apparent Low Bidders			
	Bidder	Completion Time	Bid Folder
1	ATSER Submitted: 6/14/2024 4:01:24 PM	Not Required	View Download
2	Alliance Geotechnical Group, Inc. Submitted: 6/14/2024 1:27:53 PM	Not Required	View Download
3	ECS Southwest LLP Submitted: 6/14/2024 12:28:46 PM	Not Required	View Download
4	Millennium Engineers Group Submitted: 6/14/2024 10:18:07 AM	Not Required	View Download

[✖ Release Bid Results](#)
Add Paper Bid

[✖ Release Bid Tab](#)

Bid Summary
Estimate:
Bidders: 4
AMLT \$: \$0.00
AMLT %: 0
Avg. Bid: \$0.00

Bids Opened On: 06/14/2024 04:33:45 PM



365 TOLLWAY COLLECTION SYSTEM INSTALLATION, INTEGRATION and MAINTENANCE PROJECT

- SEPTEMBER 8, 2022** -Request for Proposals was released
- OCTOBER 3, 2022** -Mandatory Pre-bid meeting was conducted with In-Person or Virtual Attendance option
- DECEMBER 9, 2022** -Five Proposals were received for the 365 Toll Collection System, Integration, and Maintenance Project
- DECEMBER 16, 2022** -Compliance reviews were conducted of all electronic bids;
- FEBRUARY 6, 2023** -Evaluation committee [HCRMA staff and HDR [GEC]] thoroughly reviewed proposals, conducted oral presentations and in accordance with RFP's two-step scoring process
- FEBRUARY 14, 2023** -Proposal bid prices opened, evaluated, scored by evaluation committee
- FEBRUARY 28, 2023** -First Executive
- MARCH 13, 2023** -Second Executive Briefing
- MARCH 14, 2023** -Negotiation of contract terms, condition, & BAFO
- MARCH 28, 2023** -Award of contract to SICE, Inc. for \$13,980,669 with a score of 905
- OCTOBER 28, 2023** -Single Gantry amendment
- March 26, 2024** - CO#1 \$645,170 for single gantery implementation

EXECUTIVE SUMMARY

- The Notice to Proceed (NTP) was issued to Pulice Construction Inc. (PCI) on February 15, 2022, with time charges commencing on March 17, 2022.
- The work under this contract shall be substantially completed within **1,264 CALENDAR** days [September 22, 2025] After Substantial Completion, Pulice will be allowed up to an additional 60 calendar days for Final Acceptance. Therefore, all improvements must be final accepted by [November 21, 2025].
- Working days will be charged Sunday through Saturday, including all holidays [with exception of:

New Year's Day (January 1st)

Independence Day (July 4th)

Labor Day (1st Monday in the month of September)

Thanksgiving Day and day after (4th Thursday and Friday in the month of November);

Christmas Eve and Day (December 24th and 25th)

regardless of weather conditions, material availability, or other conditions not under the control of the Contractor, except as expressly provided for in the Contract. If Contractor fails to complete the work on or before the contract time, Pulice Construction Inc. agrees to pay the Authority \$ 16,500 per day as liquidated damages to cover losses, expenses and damages of the Authority for every Calendar Day which the Contractor fails to achieve Substantial Completion of the Project.

- The total construction cost submitted \$ 295,932,420.25.

HCRMA 365 TOLL PROJECT CSJ#0921-02-368: CHANGE ORDER SUMMARY

Four (5) approved Changes Order(s): **[\$9,711, 974.93]** +0 days

CO#1	11/11/2021 entering VECP process	+000 days	\$000,000,000.00	.0%
CO#2	12/21/2021 VECP Plan Revisions	+000 days	\$(14,208,622.30)	(4.80%)
CO#3	04/26/2022 VECP Contractor Risk	+000 days	\$000,000,000.00	(0%)
CO#4	01/24/2023 Drill Shafts	+000 days	\$171,516.59	0.06%
CO#5	06/24/2023 VECP True Realized Savings	+000 days	\$4,325,130.78	1.44%
CO#6	11/29/2023 Plan Revisions \ Work Change Directives	+000 days	\$825,579.49 [PENDING]	0.31%

CHANGE ORDERS:

Change Order No.1 Summary: November 10, 2021, Resolution 2021-54

- The Primary purpose of Change Order No. 1 is for the HCRMA and contractor to enter a defined VECP proves to reduce the overall cost of the project based on a 30% design furnished by the contractor.
- Cost to the Project include: 30% of 5% of the project savings to the project or direct costs to the contractor, whichever is less. These costs are intended to pay the contractor for design work achieve a 30% design.
- The HCRMA assumes ownership of all design work developed by the contractor, and cost savings are shared by the HCRMA and contractor by 40% and 60% respectively.

Change Order No. 2 Summary: December 20, 2021, Resolution 2021-78

- Change order No. 2 amended the contract price from \$295,932,420.25 to \$281,723,797.95.
- By execution of Change Order No. 1, the contractor completed a 30% design to an effort to estimate cost savings for the project. Payment for the contractor's initial design work is \$613,285.06 in accordance with calculations presented in Change Order No. 1. This is the only cost due to the contractor based on the execution of Change Order No. 2 and is non-participating.
- Notice to proceed was issued 2/15/2022, the HCRMA reimburse the contractor for the remaining design costs to not exceed 5% of the total cost savings. Payments made will be based upon design milestones at 60%, 90% and 100% completion and acceptance.

VECP calculations for Contract Price of	\$281,723,797.95	
VECP Gross Savings	\$38,010,382.63	
Less est. Total Design Cost	\$1,943,648.45	(Schematics + Final Design)
Less Est. Owner's Fees	\$545,178.43	(GEC, Environmental, T&R Costs)
VECP Net Savings	\$35,521,555.75	
60% Contractor Saving:	\$21,312,933.45	Paid as Progress Payments
40% Owner Savings:	\$14,208,622.30	Reduced from original Project

Change Order No. 3 Summary: April 26, 2022, Resolution 2022-36

- As provided for Contract Amendment #1 and Change Order No. 2, the Contractor's share of the net savings includes the "Contractor Risk" that the actual costs of implementing the approved VECP concepts in Change Order No. 2 may not result in the saving approved by the parties. To the extent total actual costs exceed the total amount approved, all overages due to errors, oversights, omissions, additions, or corrections to final units, final quantities, or final unit prices or costs increases shall be deducted from Contractor 60% portion of the net savings.
- To the extent actual costs exceed the amounts presented in Exhibit A, Contractor agrees that such overages due to errors, oversight, omission additions, or corrections to final units, quantities or unit pricing shall be deducted from contractor's 60% portion of the net savings (the "Contractor Risk").
- Contractor VECP Savings Payments.

Contractor's share of the savings shall be calculated and paid out as progress payments under the terms of the contract, as follows:

Construction Progress	Proposed Savings Payment
20% Completion	\$4,262,586.69
40% Completion	\$4,262,586.69
60% Completion	\$4,262,586.69
80% Completion	\$4,262,586.69
Final Acceptance	<u>\$4,262,586.69</u>
	\$21,312,933.45

The parties agrees that if the Savings are not apparent or justified during a designated progress period, all, or part of any such Savings Payment, on the recommendation of the General Engineering Consultant, may be (i) deferred to the next progress period or (iii) reduced to reflect the Contractor's Risk for unrealized Savings/overages.

Change Order No. 4 Summary: January 24, 2023, Resolution 2023-05

Change Order No. 4 removes 1,524LF of Item 416-6005 Drill Shaft (42") introduces 48" drill shafts to incorporate detailed, finalized quantities and unit costs; and establishes State/Federal participation on odified unit costs, assuring compliance with the standard specifications included within the contract. Change Order No. 4 introducing 1,585LF of Item 416-6006 Drill Shaft (48 IN) at a unit cost of \$308.39/LF for a net cost of \$171,516.59 to be fully paid by HCRMA [Owner].



Change Order No. 5 Summary: June 24, 2023, Resolution 2023-30

In Lieu of \$38,010,382.63 savings, they only can truly account for \$30,565,888. They are claiming that of the \$7,444,494.63 shortfall, only \$3,186,525.45 is from their 60%; additional \$4,257,969.18 are contributable to busts in original plans, design errors and quantity mistakes and are to be attributed to HCRMA contingency[\$ 5,000,000>>\$570,514.23].

- As provided for Contract Amendment #1 and Change Order No. 2, the Contractor’s share of the net savings includes the “Contractor Risk” that the actual costs of implementing the approved VECP concepts in Change Order No. 2 may not result in the saving approved by the parties. To the extent total actual costs exceed the total amount approved, all overages due to errors, oversights, omissions, additions, or corrections to final units, final quantities, or final unit prices or costs increases shall be deducted from Contractor 60% portion of the net savings. **The unrealized savings presented are \$2,367,208.20**
 - To the extent actual costs exceed the amounts presented in Exhibit A, Contractor agrees that such overages due to errors, oversight, omission additions, or corrections to final units, quantities or unit pricing shall be deducted from contractor’s 60% portion of the net savings (the “Contractor Risk”), **revised shall be \$18,945,725.25**
 - Contractor VECP Savings Payments **are amended, as such:**

Contractor’s share of the savings shall be calculated and paid out as progress payments under the terms of the contract, as follows:

Construction Progress	Proposed Savings Payment	Paid Date
**20% Completion	\$4,262,586.69	12/22/22
40% Completion	\$4,262,586.69 \$3,670,784.64	
60% Completion	\$4,262,586.69 \$3,670,784.64	
80% Completion	\$4,262,586.69 \$3,670,784.64	
Final Acceptance	\$4,262,586.69 \$3,670,784.64	
	\$21,312,933.45 \$18,945,725.25	

**[\$18,945,725.25 - \$4,262,586.69 = \$14,683,138.56 / 4 = \$3,670,784.64]



Change Order No. 6 Summary:

| CHANGE ORDERS \ WORK CHANGE DIRECTIVES

CO6 DEPOT ROAD [SB Frontage at SP115] DCN 31	
CO7 Conflict Manhole STA 649 DCN32	\$(15, 838.92)
WCD1 Dicker Rd D-Inlets DCN33	\$ 13,116.99
WCD2 Changes Irrigation at Sta. 895+04 DCN34	\$35, 119.36
	\$ 21, 320.00
CO8 FM 494 Water Line – Drill Shafts Conflict DCN35	\$20,932.00
CO9 18", 30", 36" LHPP DCN37	\$0.00
WCD4 McColl Road Driveways DCN41	\$23,451.22
WCD3 TCP Appurtenances at Jackson/US281 DCN38	\$169,669.86
WCD6 Water line at US281 DCN53	\$ 345,209.78
WCD5 Ground Mounted Cabinets DCN 49	\$212,599.20
	\$825,579.49

PROJECT PRODUCTION

□ CAPTURING VECP PACKETS

- 2/8/23 VECP Team met, exchanged concepts, formats
- 3/8/23 VECP meeting formal report submitted
- 4/20/23 VECP concepts completed and negotiations underway
- 7/07/23 New revised baseline schedule
- 7/10/23 CO#5 terms and conditions
- 2/23/24 CO#6 conditions and negotiations

□ FORMAL SUBMITTALS, REVIEW OF DOCUMENTS

- RFIs 192
- SUBMITTALS 183

□ TESTING [Soils/Concrete]

- Levees / embankment / select fill
- Drill Shafts / Bents / Slab
- Roadway: limed subgrade / Cement Treated base
- MSE backfill
- Irrigation Structures

□ ENVIRONMENTAL JUSTICES [SW3Ps] Archeological sites

□ EMBANKMENT Shary / SH336 / SP115 / Highline/ McColl /Anaya

□ UNDERGROUND WORK Storm Sewer / Irrigation structures / Tolling Conduit

□ LEVEE WORK

□ Bridge Substructure FM494 / Floodway / SP115 / SH336 / McColl / Ditch Bridge / Highline

- BEAMS SET: McColl / Canal Bridge / Floodway/ FM494

□ RETAINING WALLS Highline / Anaya / SP115/ SH336 / Jackson

Business: HCRMA
Project Name: 365 TOLL PROJECT CSJ:0921-02-368
Project Description: GREENFIELD PROJECT, PRINCIPAL ARTERIAL, CONTROLLED ACCESS HIGHWAY, TOLL IMPROVEMENT, CSJ: 0921-02-368
Prime Contractor: PULICE CONSTRUCTION, INC.
Notice to Proceed Date: 2/15/2022
Construction Start Date: 3/17/2022
Awarded Project Amount: \$295,932,420.25
Net Change by Change Orders: (\$30,806,331.66)
Authorized Project Amount: \$265,126,088.59
% Complete Paid Awarded Amount: 41.327
% Complete Paid Authorized Amount: 46.129

Payment History:

Payment Number	Pay Period Start	Pay Period End	Payment Amount	Payment To Date	Payment Status	Percent Production %	
						MONTHLY	ACCUM
27	5/16/2024	6/15/2024	\$3,637,006.93	\$125,935,864.87	Pending	1.372	47.5
26	4/16/2024	5/15/2024	\$2,271,351.76	\$122,298,857.94	Paid	0.857	46.129
25	3/16/2024	4/15/2024	\$5,798,909.13	\$120,027,506.18	Paid	2.187	45.272
24	2/16/2024	3/15/2024	\$2,969,884.58	\$114,228,597.05	Paid	1.12	43.085
23	1/16/2024	2/15/2024	\$4,352,674.67	\$111,258,712.47	Paid	1.642	41.964
22	12/16/2023	1/15/2024	\$3,798,704.58	\$106,906,037.80	Paid	1.433	40.323
21	11/16/2023	12/15/2023	\$7,678,808.97	\$103,107,333.22	Paid	2.896	38.89
20	10/16/2023	11/15/2023	\$6,172,155.46	\$95,428,524.25	Paid	2.328	35.994
19	9/16/2023	10/15/2023	\$5,115,697.33	\$89,256,368.79	Paid	1.93	33.666
18	8/16/2023	9/15/2023	\$7,157,089.08	\$84,140,671.46	Paid	2.7	31.736
17	7/16/2023	8/15/2023	\$5,532,158.94	\$76,983,582.38	Paid	2.087	29.037
16	6/16/2023	7/15/2023	\$2,803,225.26	\$71,451,423.44	Paid	1.057	26.95
15	5/16/2023	6/15/2023	\$2,402,150.75	\$68,648,198.18	Paid	0.906	25.893
14	4/16/2023	5/15/2023	\$1,672,812.23	\$66,246,047.43	Paid	0.631	24.987
13	3/16/2023	4/15/2023	\$2,302,505.87	\$64,573,235.20	Paid	0.868	24.356
12	2/16/2023	3/15/2023	\$1,571,621.63	\$62,270,729.33	Paid	0.593	23.487
11	1/16/2023	2/15/2023	\$1,519,297.77	\$60,699,107.70	Paid	0.573	22.894
10	12/16/2022	1/15/2023	\$943,705.68	\$59,179,809.93	Paid	0.356	22.321
9	11/15/2022	12/15/2022	\$8,892,613.75	\$58,236,104.25	Paid	3.354	21.965
8	10/15/2022	11/14/2022	\$4,085,602.35	\$49,343,490.50	Paid	1.541	18.611
7	9/16/2022	10/14/2022	\$1,427,873.36	\$45,257,888.15	Paid	0.539	17.07
6	8/19/2022	9/15/2022	\$657,136.92	\$43,830,014.79	Paid	0.248	16.532
5	7/20/2022	8/18/2022	\$378,458.17	\$43,172,877.87	Paid	0.143	16.284
4	6/21/2022	7/19/2022	\$2,793,575.17	\$42,794,419.70	Paid	1.054	16.141
3	6/1/2022	6/20/2022	\$2,336,832.39	\$40,000,844.53	Paid	0.881	15.087
2	5/1/2022	5/31/2022	\$14,029,200.82	\$37,664,012.14	Paid	5.292	14.206
1	2/15/2022	4/30/2022	\$23,634,811.32	\$23,634,811.32	Paid	8.915	8.915

Total: **\$125,935,864.87**

MOH:	TOTAL VALUE	RECOVERED VALUE	REMAINING VALUE
	\$34,137,964.19	\$10,560,833.91	\$23,577,130.28

General Information

Project

Work Type
Heavy Highway

Location



Texas Parks & Wildlife, CONANP, Esri, Tom... Powered by Esri

Coordinates
26.14052384945899, -98.24062242016183

Location
FM-396 (ANZALDUAS HIGHWAY) TO US-281 MILITARY HIGHWAY

Management

Prime Contractor
PULICE CONSTRUCTION, INC.

Project Manager
Ramon Navarro, IV, P.E.

Managing Office
HCRMA Construction Department

Created By
Sergio Mandujano

Awarded Amount
\$295,932,420.25

Authorized Amount
\$265,126,088.59

Approved Changes
-\$30,806,331.66

Description

GREENFIELD PROJECT, PRINCIPAL ARTERIAL, CONTROLLED ACCESS HIGHWAY, TOLL IMPROVEMENT, CSJ: 0921-02-368

Amount Paid

Amount paid so far
\$122,298,857.94



Important Dates

Date Created
Apr 22, 2022

Notice to Proceed
Feb 15, 2022

Construction Start
Mar 17, 2022

Work Completion
Sep 22, 2025

Progress

Time Complete: 826 Days

Time Remaining: 438 Days



Amount Posted: \$102,584,994.26

Awarded Amount: \$295,932,420.25

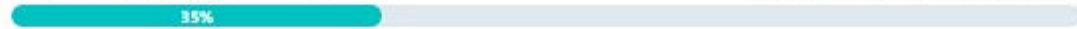

Amount Posted: \$102,584,994.26

Authorized Amount: \$265,126,088.59

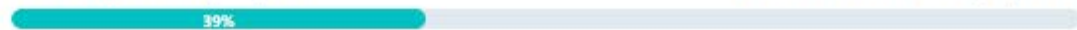

Total Retainage
\$0.00

Retainage Released
\$0.00

Liquidated Damages
\$0.00

GRANJENO / ANZALDUAS (LOOKING EAST)



Using the resulting MODULUS 7.0 results, HVJ estimated a composite modulus of reaction “k” value for the complete support system using the stress analysis tool in the TxDOT FPS21 software. The “k” value was estimated by modeling the plate load modeled stress in psi and dividing this stress by the estimated resulting surface deflection in inches. The calculated values can be compared to the 457 or 432 psi/in “k” design values used in the original pavement design thickness calculations for the CRCP pavement using the TXCRCPME for CH and CL subgrade soils respectively. Figure 1 below shows a typical output from the FPS stress analysis model. **Appendix C** contains all the FPS 21 outputs.

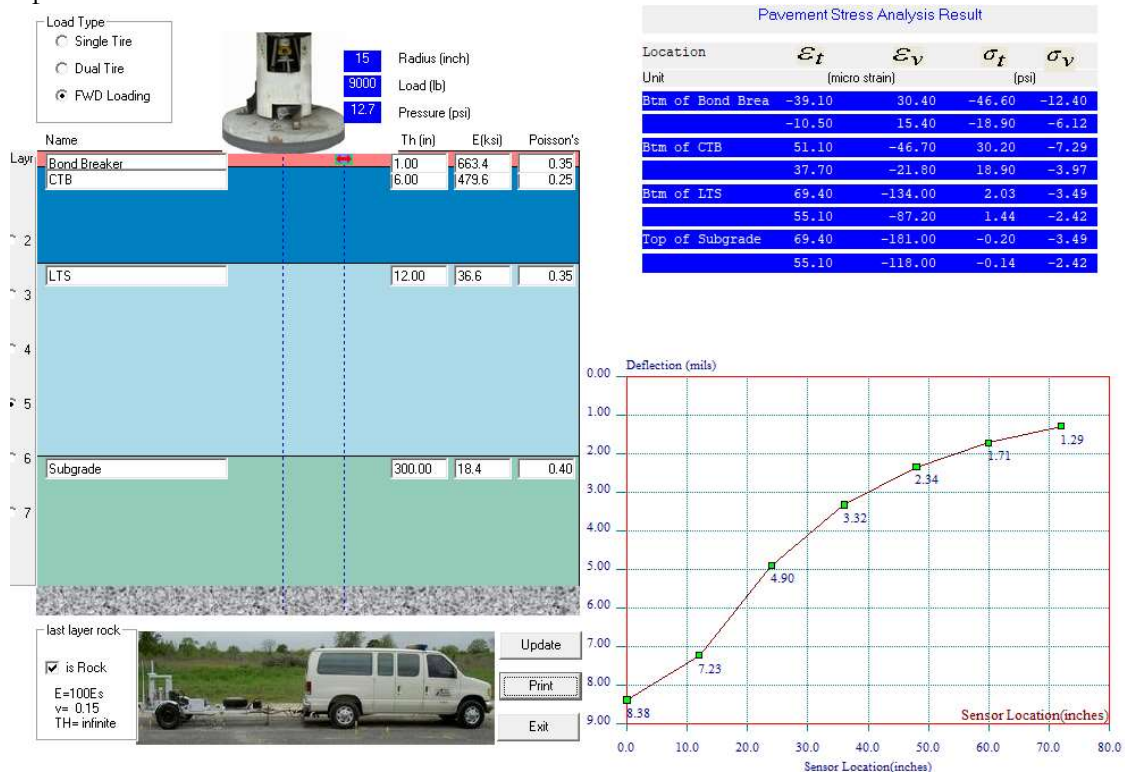

Figure 1. Typical output from the FPS 21 stress analysis model.

Summary

Table 1 provides the resulting calculations:

Table 1. Summary of the K value calculations.

Segment	Backcalculated Layer Modulus (ksi)				Max Deflection Under Plate (mils)	Plate Pressure (psi)	K value (psi/in.)
	Bond Breaker	CTB	LTS	Subgrade			
Main Lane EB 706-716	663.4	1348.2	46.5	25.6	5.7	12.7	2228
Main Lane WB 716-706	663.4	839.3	47.8	23.8	6.3	12.7	2009
Section 1 Anzalduas Road WB	663.4	109.0	29.6	18.9	10.4	12.7	1221
Section 2 East Bound Frontage	663.4	153.7	18.1	11.2	15.2	12.7	836
Section 3 Main Lane	663.4	1067.3	47.1	29.2	5.5	12.7	2330
Section 4 West Bound Frontage	663.4	479.6	36.6	18.4	8.4	12.7	1516
						Min	836

- 1.) Deflection of less than 11.1 and E>500KSI stays in place.
- 2.) Deflection of less than 11.1 and E<500KSI, coring should occur.

TTI MODULUS ANALYSIS SYSTEM (SUMMARY REPORT)

Testing would occur from lowest modulus value to highest. If non-erodible base achieved, remainder can stay.

District	0	Modulus Range (psi)	
County	0	Minimum	Maximum
Highway/Road		663.40	663.40
	Pavement:	1.00	663.40
	Base:	6.00	100.00
	Subbase:	12.00	10.00
	Subgrade:	Semi-Infinite	10.00
			0.35
			0.25
			0.35
			0.40

Station	Load (lbs)	W1	W2	W3	W4	W5	W6	W7	SURF(E1)	BASE(E2)	SUBB(E3)	SUBG(E4)	Absolute Err/Sens	Depth to Rock	Limit
0	8676	29.44	16.96	9.57	5.93	4.06	3.26	2.62	663.4	100.0	10.0	11.5	4.27	294.8	*
30	8676	10.03	6.04	4.08	3.11	2.28	2.14	1.82	663.4	355.8	50.0	22.7	5.68	300.0	*
60	8676	7.57	5.19	3.70	3.03	2.20	1.95	1.73	663.4	1354.4	50.0	23.7	6.27	300.0	*
90	8807	8.44	5.33	3.59	3.11	2.24	2.07	1.79	663.4	814.0	50.0	24.5	9.89	300.0	*
120	8709	10.29	6.84	4.47	3.37	2.55	2.20	1.73	663.4	389.3	50.0	20.5	3.03	300.0	*
150	8720	9.71	6.33	4.04	3.09	2.26	1.97	1.74	663.4	397.8	50.0	22.9	3.51	300.0	*
180	8687	10.17	6.17	4.11	2.98	2.22	1.98	1.66	663.4	316.1	50.0	23.0	3.24	300.0	*
210	8753	9.35	5.83	4.07	2.86	2.35	1.98	1.88	663.4	477.0	50.0	23.7	5.48	300.0	*
241	8643	8.81	6.29	4.46	3.37	2.50	2.17	1.72	663.4	823.0	50.0	20.4	3.07	300.0	*
270	8621	9.38	6.25	4.26	3.30	2.42	2.02	1.76	663.4	543.7	50.0	21.4	3.66	300.0	*
300	8676	9.69	6.50	4.45	3.23	2.27	2.19	1.73	663.4	468.6	50.0	21.3	4.02	300.0	*
330	8643	8.80	5.65	3.85	2.80	2.08	1.93	1.56	663.4	538.2	50.0	24.6	4.46	300.0	*
360	8753	9.72	5.86	3.73	2.91	2.22	1.92	1.81	663.4	359.5	50.0	24.4	6.10	300.0	*
390	8621	8.70	5.35	3.72	2.81	2.31	1.93	1.70	663.4	631.4	50.0	24.3	7.54	300.0	*
420	8720	7.20	4.62	3.08	2.61	2.09	1.77	1.50	663.4	1298.7	50.0	27.8	10.57	300.0	*
450	8654	5.97	4.16	3.04	2.53	1.91	1.74	1.50	663.4	2500.0	50.0	28.5	8.20	300.0	*
480	8753	10.96	5.80	3.22	2.42	1.79	1.66	1.37	663.4	169.8	50.0	29.0	3.96	300.0	*
510	8665	6.91	4.22	2.77	2.11	1.55	1.50	1.10	663.4	851.7	50.0	34.6	9.04	300.0	*
540	8577	5.19	3.61	2.48	2.24	1.71	1.39	1.28	663.4	2500.0	50.0	34.1	10.50	300.0	*
570	8413	6.37	4.11	2.85	2.34	1.80	1.54	1.25	663.4	1607.7	50.0	30.1	9.22	300.0	*
600	8544	7.64	4.67	3.21	2.56	1.92	1.77	1.35	663.4	891.0	50.0	27.5	8.97	300.0	*
629	8654	6.03	3.99	3.13	2.73	2.12	1.90	1.60	663.4	2500.0	30.4	31.1	14.95	300.0	*
660	8643	6.69	4.91	3.95	3.24	2.51	2.09	1.77	663.4	2256.9	50.0	22.6	6.84	300.0	*
690	8621	6.71	4.83	3.67	2.97	2.22	1.97	1.61	663.4	2378.1	50.0	23.8	5.80	300.0	*
720	8621	6.70	4.69	3.68	3.13	2.32	2.15	1.58	663.4	2321.4	50.0	23.2	8.41	300.0	*
750	8621	8.08	5.57	3.69	3.23	2.57	2.34	1.84	663.4	1268.7	50.0	21.6	9.76	300.0	*
799	8566	6.24	4.22	3.16	2.81	2.16	1.91	1.50	663.4	2500.0	14.1	36.6	19.09	300.0	*
810	8753	5.52	3.83	3.22	2.52	2.04	1.74	1.57	663.4	2500.0	50.0	29.9	10.06	300.0	*
840	8687	6.45	4.19	3.25	2.72	2.04	1.92	1.53	663.4	2500.0	50.0	26.5	9.65	300.0	*
873	8621	5.51	4.16	3.23	2.80	2.06	1.88	1.57	663.4	2500.0	26.1	29.3	15.29	300.0	*
901	8566	6.67	4.67	3.81	2.76	2.17	1.91	1.68	663.4	2343.6	50.0	24.1	5.07	300.0	*
930	8687	7.65	4.93	3.69	2.79	2.28	1.90	1.61	663.4	1266.1	50.0	24.6	7.40	300.0	*
960	8764	6.84	4.52	3.26	2.57	1.99	1.70	1.48	663.4	1616.1	50.0	28.0	7.56	300.0	*
990	8632	5.66	3.81	2.93	2.54	2.02	2.02	1.61	663.4	2500.0	50.0	29.6	13.46	300.0	*
Mean:		8.39	5.41	3.75	2.93	2.21	1.96	1.63	663.4	1348.2	46.5	25.6	7.76	300.0	
Std.Dev:		4.06	2.23	1.15	0.62	0.40	0.31	0.25	0.0	900.4	10.2	4.8	3.80	0.9	
Var Coeff(%):		48.43	41.16	30.65	21.24	18.21	15.81	15.33	0.0	66.8	21.9	18.8	49.40	0.3	

DATE: 8/11/2017 4:25:06 PM
 FILE: c:\projectwise\dannenbaum-hcrma\workdir\arndt.trevino\dms33735\SH365_0032_Pr1Lay_1.dgn

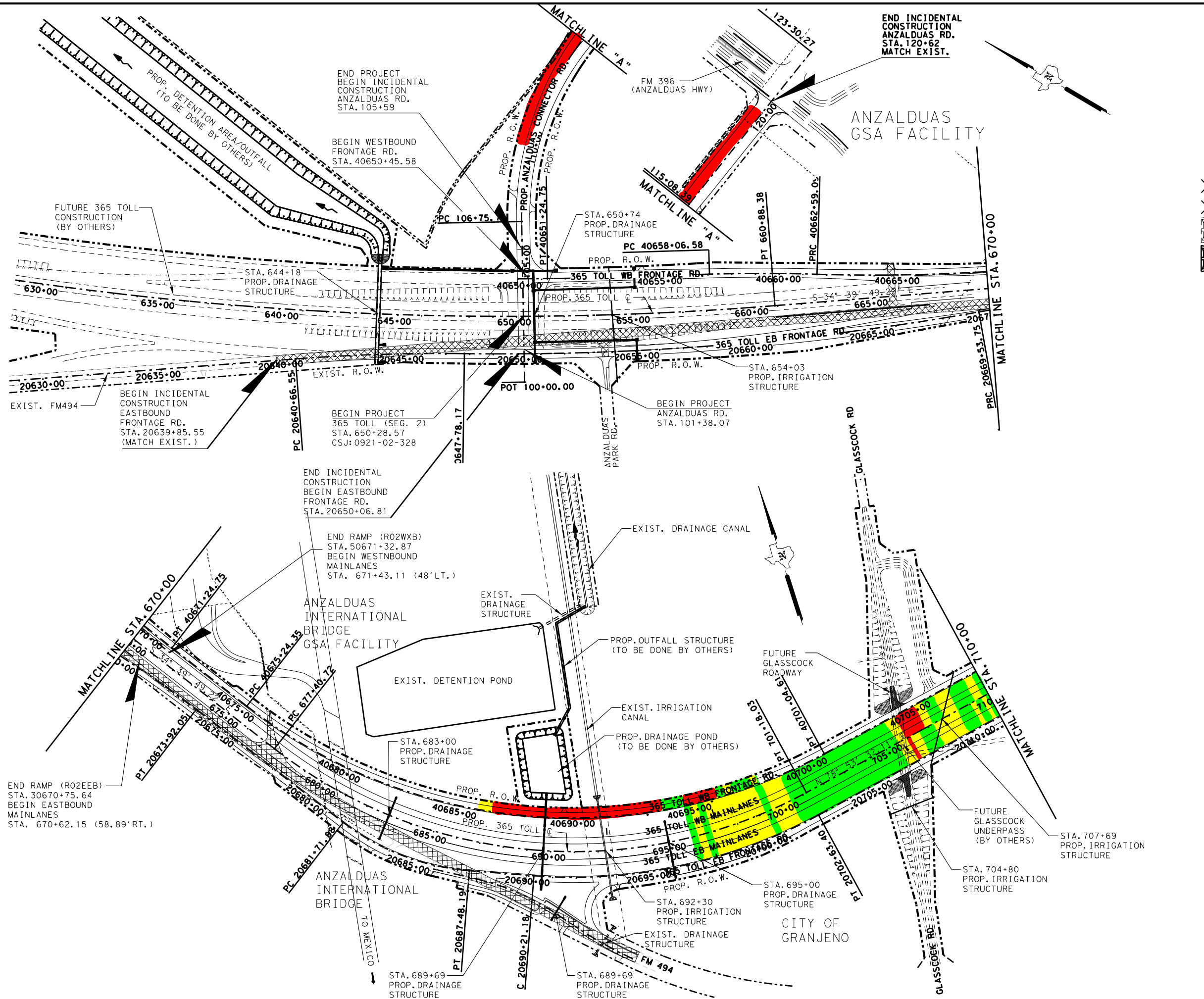

LEGEND:

- ROAD TO BE OBLITERATED
- PROP. PLANING (0-1 1/2")
- PROPOSED WIDENING & OVERLAY
- APPROXIMATE ARCHEOLOGICAL AREA
- EXIST. DRAINAGE STRUCTURE/CHANNEL
- PROP. DRAINAGE STRUCTURE/CHANNEL
- EXIST. IRRIGATION STRUCTURE
- PROP. IRRIGATION STRUCTURE
- PROPOSED CONC. RIPRAP
- DRAINAGE FLOW DIRECTION

PROGRAM MANAGEMENT CONSULTANT
DANNENBAUM
ENGINEERING CORPORATION
T.B.P.E. FIRM REGISTRATION #392
 1109 NOLANA LOOP, STE 208 MCALLEN, TX 78504 (956) 582-2677

L & G Engineering
Highway / Civil
 Structural / Bridge
 Environmental
 Firm No. : F-4105

365 TOLL PROJECT LAYOUT
STA. 630+00 TO STA. 710+00

SCALE: 1" = 400'

SHEET 1 OF 8

DN:	CONT	SECT	JOB	HIGHWAY
CK DN:	0921	02	368	365 TOLL
DW:	DIST	COUNTY	SHEET NO.	
CK DW:	PHR	HIDALGO	8	
TR:				
CK TR:				

This sheet was not changed as part of the VECP design process and remains in its original IFC state.

DATE: 6/19/2017 2:18:05 PM
 FILE: c:\projectwise\dannenbaum-hcrma\work\kd\raime.rocha\dms33735\SH365_0032_Pri+Lay_2.dgn

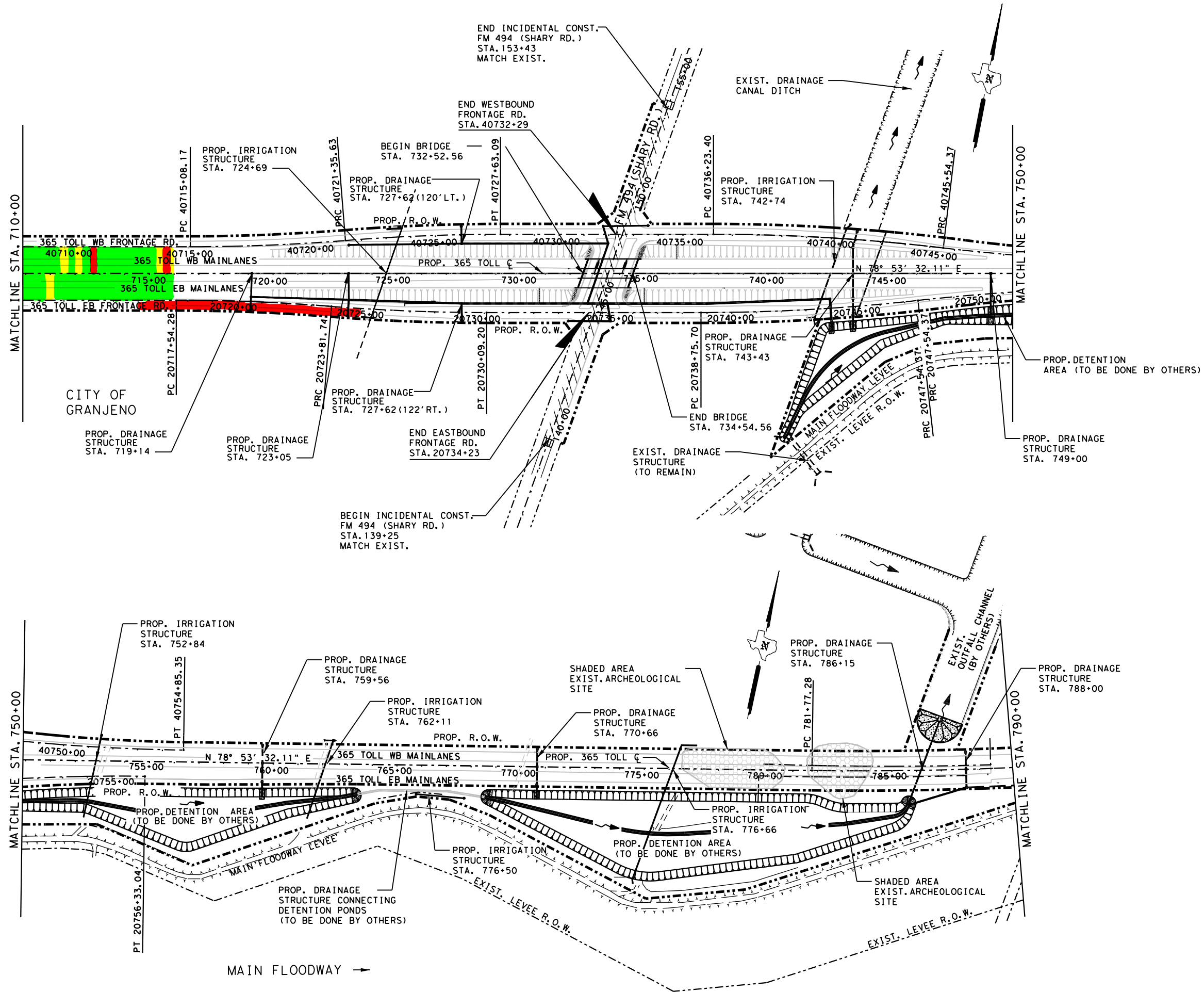

LEGEND:

- ROAD TO BE OBLITERATED
- PROP. PLANING (0-1/2")
- PROPOSED WIDENING & OVERLAY
- APPROXIMATE ARCHEOLOGICAL AREA
- EXIST. DRAINAGE STRUCTURE/CHANNEL
- PROP. DRAINAGE STRUCTURE/CHANNEL
- EXIST. IRRIGATION STRUCTURE
- PROP. IRRIGATION STRUCTURE
- PROPOSED CONC. RIPRAP
- DRAINAGE FLOW DIRECTION

STATE OF TEXAS
 CHRISTOPHER R. RODRIGUEZ
 107692
 LICENSED PROFESSIONAL ENGINEER
 06/19/2017

HCRMA
 HIDALGO COUNTY REGIONAL MOBILITY AUTHORITY

©2017
 Texas Department of Transportation

PROGRAM MANAGEMENT CONSULTANT
DANNENBAUM
 ENGINEERING CORPORATION
 T.B.P.E. FIRM REGISTRATION #392
 1109 NOLANA LOOP, STE 208 MCALLEN, TX 78504 (956) 682-3677

L&G Engineering
 Highway / Civil
 Structural / Bridge
 Environmental
 Firm No.: F-4105
 2100 W. Expressway 83
 Mercedes, TX 78570
 Phone: (956) 565-9813
 Fax: (956) 565-9018
 900 S. Stewart Rd., Ste. 10
 Mission, TX 78572
 Phone: (956) 585-1909
 Fax: (956) 585-1927

365 TOLL PROJECT LAYOUT
 STA. 710+00 TO STA. 790+00

SCALE: 1" = 400' SHEET 2 OF 8

DN:	CONT	SECT	JOB	HIGHWAY
CK DN:	0921	02	368	365 TOLL
TR:	DIST	COUNTY	SHEET NO.	
CK TR:	PHR	HIDALGO	9	

This sheet was not changed as part of the VECP design process and remains in its original IFC state.



June 05, 2024 11:14 AM



June 05, 2024 11:32 AM



June 05, 2024 11:15 AM



Memo

Date: Wednesday, June 05, 2024

Project: 365 Toll Project (Seg 1 & 2)

To: Rafael Carmona

CC: Pilar Rodriguez

From: Samuel Saldivar, Ramon Navarro, Dan Paredes

Subject: Concrete Paving Operations – Stop Work Notice

This memo is formal notice by the Authority to Pulice Construction, Inc (PCI) to suspend concrete pavement construction operations until further notice.

The concrete paving construction operation is suspended until TxDOT and FHWA approve PCI's pavement design. The following items are under TxDOT and FHWA review:

- SH 288 Material Testing Data
 - The Authority has requested this information prior to contract execution during VECP concept reviews. This information has always been tied to the justification of the pavement design. PCI is required to submit this information.
- Cement Treated Base (CTB) Test Results
 - Item 276 requires a 7-day compressive strength of 500psi or greater
- CTB coring results
- CTB corrective measures approach
- Concrete Pavement Flexural Strength tests
 - Pavement Design requires a 28-day strength equal to or greater than 720psi

The Authority is requesting PCI's approach to consistently meeting the concrete pavement 720psi flexural strength (i.e. mix design, curing operation, etc.). Keep in mind, the Authority has only entertained modification of the concrete flexural strength. PCI is required to meet all other concrete testing and performance requirements of Item 360. In addition, the flexural strength test for the 720psi becomes part of the QA material testing requirements.

Once TxDOT and FHWA provide an official approval of the pavement design and field corrective measures, the Authority will notify PCI of said corrective measures and notice to continue paving construction operations.

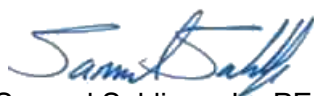

Samuel Saldivar, Jr., PE



Ramon Navarro IV, PE





June 07, 2024 9:03 AM





Memo

Date: Thursday, June 06, 2024

Project: 365 Toll Project (Seg 1 & 2)

To: Rafael Carmona

CC: Pilar Rodriguez

From: Samuel Saldivar, Ramon Navarro, Dan Paredes

Subject: Retaining Wall Panel Casting – Stop Work Notice

This memo is formal notice by the Authority to Pulice Construction, Inc (PCI) to suspend casting of concrete retaining wall panels until further notice.

The retaining wall panel casting construction operation is suspended until the following issues are resolved:

- Uncertified Field-Testing Technicians Item 9.4.2
 - as per DMS-7300
- 10.3 per DMS-7300
- Full compliance of PCI submitted QC/QA Plan
- Unapproved Concrete Mix Design
 - Need to provide the Authority 7-days to review concrete mix design submittal as per Item 424.
- Signed / Authorized approval from retaining wall engineer-of-record or technician-of-record on PCI's wall construction operations (i.e. backfill type plus test results, reinforcement strap connections)

Since PCI is not utilizing pre-cast retaining wall panels from a TxDOT approved supplier, PCI is required to meet the requirements of Item 424 and is responsible for executing the testing outlined in DMS-7300. Once all issues have been resolved, The Authority will notify PCI of said corrective measures and notice to continue retaining wall concrete casting operations.

Samuel Saldivar, Jr., PE

Ramon Navarro IV, PE







BRIDGE
MAY ICE IN
COLD
WEATHER

West Military
to Hwy 101
via 101

June 14, 2024 9:08 AM









June 07, 2024 10:01 AM



STA 729+00
South side



STA 729+00



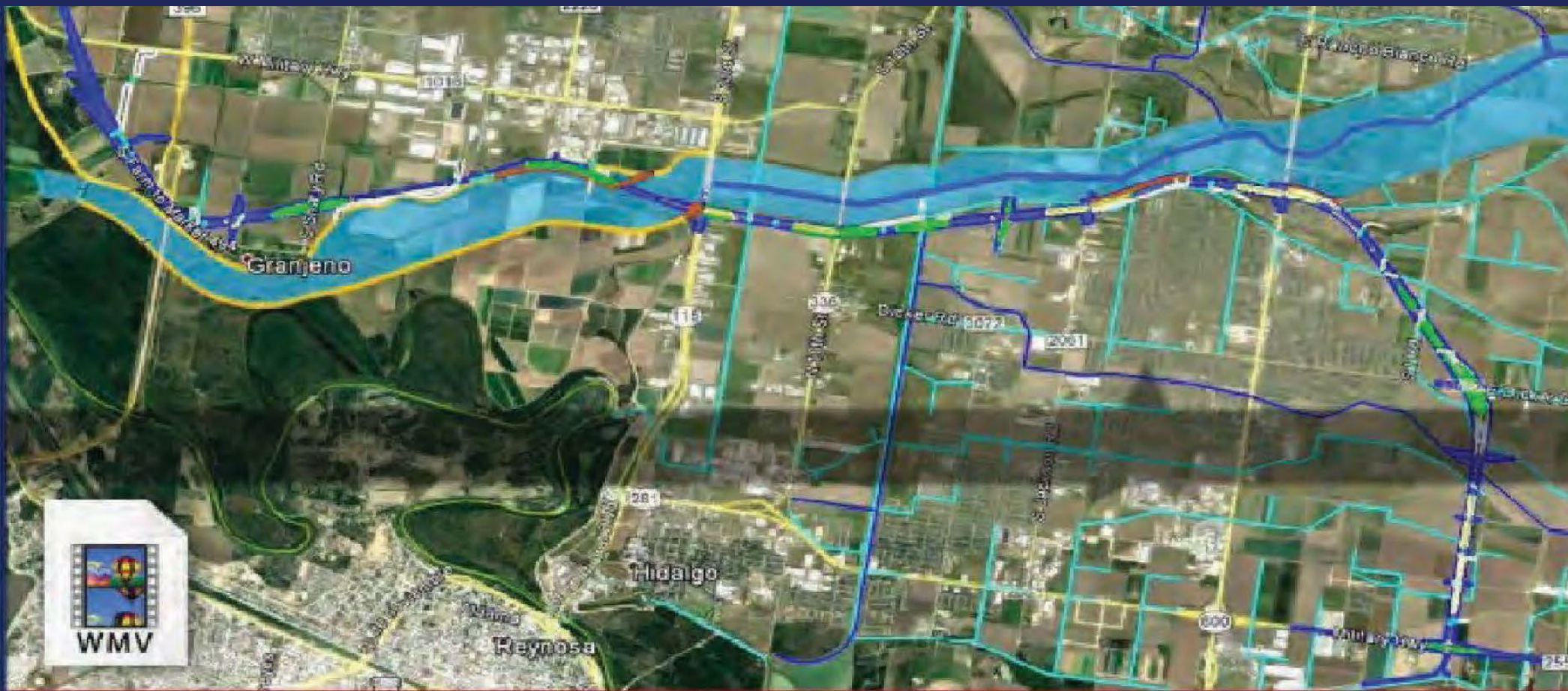

THIS ITEM WILL BE
SENT UNDER
SEPERATE COVER

This Page
Intentionally
Left Blank

Item 2A

HIDALGO COUNTY REGIONAL MOBILITY AUTHORITY

AGENDA RECOMMENDATION FORM

BOARD OF DIRECTORS	<u> X </u>	AGENDA ITEM	<u> 2A </u>
PLANNING COMMITTEE	<u> </u>	DATE SUBMITTED	<u> 06/17/2024 </u>
FINANCE COMMITTEE	<u> </u>	MEETING DATE	<u> 06/25/2024 </u>
TECHNICAL COMMITTEE	<u> </u>		

1. Agenda Item: **APPROVAL OF MINUTES FOR THE BOARD OF DIRECTOR'S REGULAR MEETING HELD MAY 28, 2024.**

2. Nature of Request: (Brief Overview) Attachments: X Yes No
Approval of Minutes for the Hidalgo County Regional Mobility Authority Board of Directors Regular Meeting held May 28, 2024.

3. Policy Implication: Board Policy, Local Government Code, Texas Government Code, Texas Transportation Code, TxDOT Policy

4. Budgeted: Yes No X N/A

5. Staff Recommendation: **Motion to approve the minutes for the Board of Director's Regular Meeting held on May 28, 2024.**

6. Program Manager's Recommendation: Approved Disapproved X None
7. Planning Committee's Recommendation: Approved Disapproved X None
8. Board Attorney's Recommendation: Approved Disapproved X None
9. Chief Auditor's Recommendation: Approved Disapproved X None
10. Chief Financial Officer's Recommendation: Approved Disapproved X None
10. Chief Development Engineer's Recommendation: Approved Disapproved X None
11. Chief Construction Engineer's Recommendation: Approved Disapproved X None
12. Executive Director's Recommendation: X Approved Disapproved None

**STATE OF TEXAS
COUNTY OF HIDALGO
HIDALGO COUNTY REGIONAL MOBILITY AUTHORITY**

The Hidalgo County Regional Mobility Authority Board of Directors convened for a Workshop and Regular Board Meeting on Tuesday, May 28, 2024, at 5:30 pm by video/teleconference, with the following participating:

- Board Members: David Deanda, Jr., Chairman (Teleconference)
Juan Carlos Del Ángel, Secretary/Treasurer
Frank Pardo, Director (Teleconference)
Gabriel Kamel, Director (Teleconference)
Sergio Saenz, Director (Teleconference)
Michael Williamson, Director
- Absent: Ezequiel Reyna, Vice-Chairman
- Staff: Pilar Rodriguez, Executive Director
Ramon Navarro, Chief Construction Engineer
Celia Gaona, Chief Auditor/Compliance Officer
Jose Castillo, Chief Financial Officer
Maria Alaniz, Executive Assistant
Richard Cantu, Law Office of Richard Cantu, Legal Counsel (Teleconference)

The Executive Director established a quorum. The Board Members in attendance unanimously elected Director Carlos Del Ángel as the presiding officer for the meeting.

PLEDGE OF ALLEGIANCE

Secretary Treasurer Carlos Del Angel led the Pledge of Allegiance.

INVOCATION

Mrs. Maria Alaniz led the invocation.

CALL TO ORDER AND ESTABLISHMENT OF A QUORUM FOR A REGULAR MEETING

Secretary Treasurer Del Angel called the Regular Meeting to order at 5:30 p.m.

PUBLIC COMMENT

No Comments

1. REPORTS

- A. Report on Program Management Activity for 365 Tollway Project – HCRMA Staff
Mr. Ramon Navarro reported on Program Manager Activity for 365 Tollway Project. No action taken.

- B. Report on Construction Activity for 365 Tollway Project – Ramon Navarro IV, HCRMA.
Mr. Ramon Navarro reported on the construction activity for 365 Tollway Project. No action taken.

2. CONSENT AGENDA

Motion by Gabriel Kamel with a second by Michael Williamson, to approve the Consent Agenda.

Motion carried unanimously.

- A. Approval of Minutes for the Regular Board Meeting held May 28, 2024.
Approved the Minutes for the Regular Board Meeting held May 28, 2024.
- B. Approval of Project & General Expense Report for the period from April 6, 2024 to May 7, 2024.
Approved the Project & General Expense Report for the period from April 6, 2024 to May 7, 2024.
- C. Approval of Financial Reports for March 2024 and April 2024.
Approved the Financial Reports for March 2024 and April 2024.

3. REGULAR AGENDA

- A. Resolution 2024-26 – Consideration and Approval of a Professional Service Agreement with SWG, Inc. to provide Construction Inspection Services for the Hidalgo County Irrigation District Number 2 Improvements as part of the 365 Tollway Project.
Motion by Frank Pardo, with a second by Michael Williamson, to approve Resolution 2024-26 – Consideration and Approval of a Professional Service Agreement with SWG, Inc. to provide Construction Inspection Services for the Hidalgo County Irrigation District Number 2 Improvements as part of the 365 Tollway Project for a lump sum fee not to exceed \$50,000.00. Motion carried unanimously.
- B. Resolution 2024-27 – Consideration and Approval of Change Order Number 6 to that Certain Construction Contract with Pulice Construction, Inc. for the 365 Tollway.
No Action.

4. CHAIRMAN’S REPORT

- A. None.

5. TABLED ITEMS

- A. None.

6. EXECUTIVE SESSION, CHAPTER 551, TEXAS GOVERNMENT CODE, SECTION 551.071 (CONSULTATION WITH ATTORNEY), SECTION 551.072 (DELIBERATION OF REAL PROPERTY), AND SECTION 551.074 (PERSONNEL MATTERS)

- A. Consultation with Attorney on legal issues pertaining to Change Order Number 5 to that certain contract with Pulice Construction Inc. for the 365 Tollway Project (551.071 T.G.C.)
No Action taken.

- B. Consultation with Attorney on legal issues pertaining to the Financial Assistance Agreement with the Texas Department of Transportation for the 365 Tollway Project (551.071 T.G.C.)
No Action taken.
- C. Consultation with Attorney on legal issues pertaining to Professional Service Agreements for Engineering, Surveying and Environmental Services (Section 551.071 T.G.C.).
No Action taken.
- D. Consultation with Attorney on legal issues pertaining to the voluntary acquisition of real property for various parcels for the 365 Tollway Project and International Bridge Trade Corridor Project (Sections 551.071 and 551.072 T.G.C.).
No Action taken.
- E. Consultation with Attorney on legal issues pertaining to the acquisition, including the use of Eminent Domain, for property required to complete the project alignments of the 365 Tollway Project (Sections 551.071 and 551.072 T.G.C.).
No Action taken.
- F. Consultation with Attorney on legal issues pertaining to the Environmental Clearance Document for the International Bridge Trade Corridor Project (Section 551.071 T.G.C.).
No Action taken.

ADJOURNMENT

There being no other business to come before the Board of Directors, motion by Michael Williamson, with a second by Frank Pardo, to adjourn the meeting at 5:57 p.m.

S. David Deanda, Jr., Chairman

Attest:

Carlos Del Ángel, Secretary/Treasurer

This Page
Intentionally
Left Blank

Item 2B

HIDALGO COUNTY REGIONAL MOBILITY AUTHORITY

AGENDA RECOMMENDATION FORM

BOARD OF DIRECTORS	<u> X </u>	AGENDA ITEM	<u> 2B </u>
PLANNING COMMITTEE	<u> </u>	DATE SUBMITTED	<u> 06/14/24 </u>
FINANCE COMMITTEE	<u> </u>	MEETING DATE	<u> 06/25/24 </u>
TECHNICAL COMMITTEE	<u> </u>		

1. Agenda Item: **APPROVAL OF PROJECT AND GENERAL EXPENSE REPORT FROM MAY 8, 2024 TO JUNE 7, 2024**

2. Nature of Request: (Brief Overview) Attachments: X Yes No

Consideration and approval of project and general expense report for the period from May 8, 2024, to June 7, 2024

3. Policy Implication: Board Policy, Local Government Code, Texas Government Code, Texas Transportation Code, TxDOT Policy

4. Budgeted: X Yes No N/A Funding Source: VRF Bond

Operating Account	\$ 281,321.86
Toll Revenue Series 2022A&B	\$ 374,820.95
Disbursement Account	\$ 0.00
VRF Series 2020A	\$ 0.00
Total Project Expenses for Reporting Period	\$ 656,142.81

Fund Balance after Expenses \$ 138,442,891

5. Staff Recommendation: **Motion to approve the project and general expense report for the May 8, 2024, to June 7, 2024, as presented.**

6. Planning Committee's Recommendation: Approved Disapproved X None

7. Finance Committee's Recommendation: Approved Disapproved X None

8. Board Attorney's Recommendation: Approved Disapproved X None

9. Chief Auditor's Recommendation: Approved Disapproved X None

10. Chief Financial Officer's Recommendation: X Approved Disapproved None

11. Chief Development Engineer's Recommendation: X Approved Disapproved None

12. Chief Construction Engineer's Recommendation: X Approved Disapproved None

13. Executive Director's Recommendation: X Approved Disapproved None



Memorandum

To: S. David Deanda Jr., Chairman
From: Pilar Rodriguez, PE, Executive Director
Date: June 14, 2024
Re: **Expense Report for the Period from May 8, 2024, to June 7, 2024**

Attached is the expense report for the period commencing on May 8, 2024, to June 7, 2024 .

Expenses for the General Account total \$281,321.86, Toll Revenue Series 2022A&B total is \$374,820.95, Disbursement Account total \$0, and the VRF Series 2020A Account is \$0. The aggregate expense for the reporting period is \$ 656,142.81.

Based on review by this office, **approval of expenses for the reporting period is recommended in the aggregate amount of \$ 656,142.81.**

This leaves a fund balance (all funds) after expenses of \$138,442,891.

If you should have any questions or require additional information, please advise.



**May 8 - June 7
June 2024**

Plains Capital 41

Make Check Payable to	Inv Date	Amount
Valero Fleet	6/15/2024	\$ 1,111.88
City of Pharr	6/4/2024	\$ 850.00
City of Pharr	6/13/2024	\$ 190,879.65
City of Pharr	5/9/2024	\$ 205.00
City of Pharr	6/13/2024	\$ 7,380.00
City of Pharr	6/12/2024	\$ 7,003.87
Carson Maps Company, Inc.	6/3/2024	\$ 595.00
Pharr Economic Development Corporation	6/4/2024	\$ 4,480.00
Law Office of Richard A. Cantu, P.C.	6/7/2024	\$ 60.00
BNP Media II, LLC	5/31/2024	\$ 2,285.00
Gannett Texas/New Mexico LocalIQ - CCT		
Corpus Caller Times	5/5/2024	\$ 850.04
New Mexico LocalIQ	5/5/2024	\$ 1,472.00
Hearst Media Solutions-Houston Chronicle	5/19/2024	\$ 3,453.00
Aim Media Texas	5/31/2024	\$ 1,115.84
A-Fast Delivery, LLC	6/5/2024	\$ 131.50
Burton McCumber & Longoria, LLP	5/8/2024	\$ 26,000.00
Pathfinder Public Affairs	5/31/2024	\$ 10,000.00
Pena Designs	6/2/2024	\$ 200.00
Xerox Financial Services	6/11/2024	\$ 591.60
Xerox Financial Services	6/11/2024	\$ 219.46
LiftOff, LLC	5/25/2024	\$ 10,788.00
Waukesha-Pearce Industries, LLC	6/6/2024	\$ 1,517.26
Jr. Leds	6/7/2024	\$ 1,200.00
ESRI	5/22/2024	\$ 3,288.50
Credit Card Services	5/3/2024	\$ 1,825.00
Credit Card Services	5/3/2024	\$ 2,398.37
Credit Card Services	5/3/2024	\$ 1,420.89
Credit Card Services	5/3/2024	\$ -
		\$ 281,321.86

Previously Paid
Check

Wilmington Trust 44/365 Project Construction & Related Costs 2022 A

Pulice Construction, Inc.	6/18/2024	\$ 3,637,006.93
SICE Inc.	6/1/2024	\$ 48,233.79
HDR Engineering, Inc.	6/11/2024	\$ 25,312.30
HDR Engineering, Inc.	6/11/2024	\$ 83,814.39
Escobedo & Cardenas, LLP	6/7/2024	\$ 2,975.00
Law Office of Richard A. Cantu, P.C.	6/7/2024	\$ 3,375.00
Atlas Technical Consultants, LLC	6/6/2024	\$ 13,520.33
Terracon Consultants, Inc.	6/6/2024	\$ 49,980.94
B2Z Engineering	6/7/2024	\$ 132,916.46
Raba Kistner, Inc.	6/4/2024	\$ 14,692.74
		\$ 4,011,827.88

Wilmington Trust 45/Capital Projects

CP

		\$ -
--	--	------

Sub Total - General -41 (Operating)	\$ 281,321.86
Sub Total - Construction/Related Costs-44 (New Bonds A)	\$ 4,011,827.88
Sub Total - Capital Projects-45 (Disbursement)	\$ -
Total	\$ 4,293,149.74

Approved: _____
S. David Deanda, Jr., Chairman

Pilar Rodriguez, Executive Director

Approved: _____
Juan Carlos Del Ángel, Secretary/Treasurer

6/25/2024

Item 2C

HIDALGO COUNTY REGIONAL MOBILITY AUTHORITY

AGENDA RECOMMENDATION FORM

BOARD OF DIRECTORS	<u> X </u>	AGENDA ITEM	<u> 2C </u>
PLANNING COMMITTEE	<u> </u>	DATE SUBMITTED	<u> 06/14/24 </u>
FINANCE COMMITTEE	<u> </u>	MEETING DATE	<u> 06/25/24 </u>
TECHNICAL COMMITTEE	<u> </u>		

1. Agenda Item: **APPROVAL OF THE FINANCIAL REPORT FOR THE MONTH OF MAY 2024**

2. Nature of Request: (Brief Overview) Attachments: X Yes No
Consideration and approval of financial report for the month of May 2024.

3. Policy Implication: Board Policy, Local Government Code, Texas Government Code, Texas Transportation Code, TxDOT Policy

4. Budgeted: Yes No X N/A

Funding Source:

5. Staff Recommendation: **Motion to approve the Financial Report for the months of May 2024, as presented.**

6. Planning Committee's Recommendation: Approved Disapproved X None

7. Finance Committee's Recommendation: Approved Disapproved X None

8. Board Attorney's Recommendation: Approved Disapproved X None

9. Chief Auditor's Recommendation: Approved Disapproved X None

10. Chief Financial Officer's Recommendation: X Approved Disapproved None

11. Chief Development Engineer's Recommendation: Approved Disapproved X None

12. Chief Construction Engineer's Recommendation: Approved Disapproved X None

13. Executive Director's Recommendation: X Approved Disapproved None

THIS ITEM WILL BE
SENT UNDER
SEPERATE COVER

This Page
Intentionally
Left Blank

Item 3A

HIDALGO COUNTY REGIONAL MOBILITY AUTHORITY

AGENDA RECOMMENDATION FORM

BOARD OF DIRECTORS	<u> X </u>	AGENDA ITEM	<u> 3A </u>
PLANNING COMMITTEE	<u> </u>	DATE SUBMITTED	<u> 06/18/2024 </u>
FINANCE COMMITTEE	<u> </u>	MEETING DATE	<u> 06/25/2024 </u>
TECHNICAL COMMITTEE	<u> </u>		

1. Agenda Item: **RESOLUTION 2024-27 – CONSIDERATION AND APPROVAL OF CHANGE ORDER NUMBER 6 TO THAT CERTAIN CONSTRUCTION CONTRACT WITH PULICE CONSTRUCTION INC. FOR THE 365 TOLLWAY.**

2. Nature of Request: (Brief Overview) Attachments: Yes No
For Change Order Number 6 to the Construction Contract with Pulice Construction Inc.

3. Policy Implication: Board Policy, Local Government Code, Texas Government Code, Texas Transportation Code, TxDOT Policy

4. Budgeted: Yes No N/A

5. Staff Recommendation: **WResolution 2024-06 – Consideration and Approval of Chang Order Number 6 to that certain Construction Contract with Pulice construction, Inc. for the 365 Tollway, as presented.**

6. Program Manager’s Recommendation: Approved Disapproved None

7. Planning Committee’s Recommendation: Approved Disapproved None

8. Board Attorney’s Recommendation: Approved Disapproved None

9. Chief Auditor’s Recommendation: Approved Disapproved None

10. Chief Financial Officer’s Recommendation: Approved Disapproved None

11. Chief Development Engineer’s Recommendation: Approved Disapproved None

12. Chief Construction Engineer’s Recommendation: Approved Disapproved None

13. Executive Director’s Recommendation: Approved Disapproved None

THIS ITEM WILL BE
SENT UNDER
SEPERATE COVER

This Page
Intentionally
Left Blank

Item 3B

HIDALGO COUNTY REGIONAL MOBILITY AUTHORITY

AGENDA RECOMMENDATION FORM

BOARD OF DIRECTORS	<u> X </u>	AGENDA ITEM	<u> 3B </u>
PLANNING COMMITTEE	<u> </u>	DATE SUBMITTED	<u> 06/18/24 </u>
FINANCE COMMITTEE	<u> </u>	MEETING DATE	<u> 06/25/24 </u>
TECHNICAL COMMITTEE	<u> </u>		

1. Agenda Item: **RESOLUTION 2024-29 – APPROVAL OF SUPPLEMENTAL AGREEMENT 2 TO WORK AUTHORIZATION 21 TO THE PROFESSIONAL SERVICES AGREEMENT WITH SAMES INC. FOR A NO-COST TIME EXTENSION TO PROVIDE SURVEYING SERVICES FOR ADDITIONAL “X” PARCELS CLAIMED BY HIDALGO COUNTY IRRIGATION DISTRICT NUMBER 2 AS PART OF THE 365 TOLLWAY PROJECT.**

2. Nature of Request: (Brief Overview) Attachments: X Yes No

Consideration and Approval of Supplemental Agreement 2 to Work Authorization 21 to the PSA with SAMES Inc. for no-cost time extension for 365 Tollway Project.

3. Policy Implication: Board Policy, Local Government Code, Texas Government Code, Texas Transportation Code, TxDOT Policy

4. Budgeted: X Yes No N/A

5. Staff Recommendation: **Motion to Approve Resolution 2024-29 – Approval of Supplemental Agreement 2 to Work Authorization 21 to the Professional Services Agreement with SAMES Inc. for a no-cost time extension to provide surveying services for additional “X” Parcels claimed by Hidalgo County Irrigation District Number 2 as part of the 365 Tollway Project, as presented.**

6. Program Manager’s Recommendation: Approved Disapproved X None

7. Planning Committee’s Recommendation: Approved Disapproved X None

8. Board Attorney’s Recommendation: Approved Disapproved X None

9. Chief Auditor’s Recommendation: Approved Disapproved X None

10. Chief Financial Officer’s Recommendation: Approved Disapproved X None

11. Chief Development Engineer’s Recommendation: X Approved Disapproved None

12. Chief Construction Engineer’s Recommendation: Approved Disapproved X None

13. Executive Director’s Recommendation: X Approved Disapproved None



- CMT Services
- Environmental
- Engineering
- Geo-Technical
- Surveying **SAMES**

WORK AUTHORIZATION SUMMARY

RESOLUTION 2024-29

Work Authorization # 21 Supplemental # 2

Amount \$ 0.00

APPROVED WORK AUTHORIZATIONS:

Resolution No.	Description	Amount
2016-24	WA 1 Revised survey services for 365	\$ 2,935.00
2016-44	WA 2 Revised parcels for 365	\$ 13,567.50
2016-58	WA 3 Revise parcels for 365	\$ 13,085.00
2016-73	WA 4 Revise parcels - approved amount \$5085	\$ 4,060.00
2016-81	WA 5 Revise parcels	\$ 22,325.00
Subtotal from Cont. Page		\$ 331,399.00
Total Approved WA		\$ 387,371.50

Proposed Work Authorization and/or Supplemental	
2024-29 WA 21 SA 2 No-cost time extension	\$ 0.00

Goals and Options:

Approval of Supplemental Agreement 2 to Work Authorization 21 to the Professional Services Agreement with SAMES Inc. for a no-cost time extension to provide surveying services for additional "X" parcels claimed by Hidalgo County Irrigation District Number 2 as part of the 365 Tollway Project.

Staff is recommending approval of this request in the amount of \$ 0.00
Proposed total approved WA and/or Supplementals \$ 387,371.50

Proposed Revised Contract Amount

R. Navarro IV, Cons Eng
Requested By:

Work Authorizations Cont...**Resolution No. 2024-29**

Resolution No.	Description	Amount
2016-98	WA No. 6 Revise parcels	\$ 4,080.00
2016-105	WA No. 7 Right of Way Staking	\$ 5,650.00
2016-112	WA No. 8 Revise parcel	\$ 1,625.00
2016-113	WA No. 9 Constuction Monuments	\$ 26,365.00
2016-123	WA No. 10 Parcel Sketches	\$ 1,270.00
2016-125	WA No. 11 Parcel Surveys	\$ 12,030.00
2017- 02	WA No. 12 Parcel Surveys	\$ 1,840.00
2017- 05	WA No. 13 Parcel Survey Updates	\$ 9,715.00
2017- 14	WA No. 14 Offsite Drainage Parcels	\$ 83,030.00
2017-15	WA No. 15 Subsurface Utility Relo	\$ 44,948.00
2017- 36	Supplemental # 2 to WA # 3	\$ 0.00
2017- 37	Supplemental # 1 to WA # 9	\$ 0.00
2017-38	WA No. 16 Parcel Surveys	\$ 3,230.00
2017-74	Suppl. No. 1 to WA No. 15 - addl SUE scope	\$ 20,926.00
2018-13	Suppl. No. 3 to WA No. 3 - No Cost Time ext	\$ 0.00
2018-17	WA No. 14 HCID2 Parcel Adjacent/Par 65P92	\$ 2,080.00
2018-56	WA No. 17 Irrigation Parcel	\$ 4,370.00
2019-04	WA No. 18 New Scope I-Road Parcels	\$ 6,350.00
2021-06	WA19 HCID2 Parcel Updates	\$ 1,180.00
2021-11	SA 1 WA19 HCID2 Parcel Updates	\$ 2,330.00
2021-16	SA 2 WA19 HCID2 Parcel Updates	\$ 3,180.00
2021-19	SA 3 WA19 HCDD #1 Re-Issue Outfall Parcels	\$ 3,595.00
2023-19	WA 20 - Surveying Services for X - Parcels	\$ 56,245.00
2023-20	WA 21 - One Corner Clip Parcel	\$ 1,800.00
2023-47	WA 20 - Surveying Services for X - Parcels	\$ 15,715.00
2024-12	WA 20 - Surveying Services for X - Parcels	\$ 19,845.00
	Subtotal	\$ 331,399.00

HIDALGO COUNTY REGIONAL MOBILITY AUTHORITY

BOARD RESOLUTION No. 2024-29

**CONSIDERATION AND APPROVAL SUPPLEMENTAL NUMBER 2 TO WORK
AUTHORIZATION NUMBER 21 TO THE PROFESSIONAL SERVICE
AGREEMENT WITH SAMES, INC. FOR A NO-COST TIME EXTENSION TO
PROVIDE SURVEYING SERVICES FOR ADDITIONAL “X” PARCELS CLAIMED
BY HIDALGO COUNTY IRRIGATION DISTRICT NUMBER 2 AS PART OF THE
365 TOLLWAY PROJECT**

THIS RESOLUTION is adopted this 25th day of June 2024 by the Board of Directors of the Hidalgo County Regional Mobility Authority at a regular meeting.

WHEREAS, the Hidalgo County Regional Mobility Authority (the "Authority"), acting through its Board of Directors (the "Board"), is a regional mobility authority created pursuant to Chapter 370, Texas Transportation Code, as amended (the "Act");

WHEREAS, the Authority is authorized by the Act to address mobility issues in and around Hidalgo County;

WHEREAS, on February 22, 2012 the Authority approved Resolution 2012-04, creating the Technical Committee, comprised of senior level engineers and professionals from various communities and agencies in the jurisdiction of the Authority, to serve to advise the Board on procurement and consultant work products; and

WHEREAS, on February 22, 2012 the Authority approved Resolution 2012-04 authorizing the Executive Committee to determine the size, structure and scope of the Technical Committee, identify candidates and issue requests for participation; and

WHEREAS, on October 16, 2013 the Authority approved Resolution 2013-41 authorizing the use and structure of the Technical Committee to rate, rank and recommend a short list to the Board of Directors for the Statements of Qualifications for the International Bridge Trade Corridor Project for Engineering, Surveying and Geotechnical Services; and

WHEREAS, on November 20, 2014, the Authority approved Resolution 2013- 53 the Technical Committee has rated and ranked the Statements of Qualifications for the International Bridge Trade Corridor Project for Surveying Services and recommended that HCRMA staff be authorized to negotiate with all qualified Surveying Firms (Halff Associates, RODS Surveying, Quintanilla, Headley & Associates, Land Tech Consultants, R. Gutierrez Engineering, Malden & Hunt, DOS Land Surveying, SAMES, Bain Medina Bain, ROW Surveying Services and Fulcrum Consulting Services) to establish a surveying pool for the project; and

WHEREAS, on June 18, 2014, the Authority approved Resolution 2014-53 awarding professional service agreements to Halff Associates, RODS Surveying, Quintanilla, Headley & Associates, Land Tech Consultants, R. Gutierrez Engineering, Malden & Hunt, DOS Land Surveying, SAMES, Bain Medina Bain, ROW Surveying Services and Fulcrum Consulting Services for surveying services for the International Bridge Trade Corridor Project; and

WHEREAS, on February 23, 2016, the Authority approved Resolution 2016- 24 Work Authorization 1 to the Professional Service Agreement with SAMES, Inc. to provide revised survey for the SH 365 Segment 1 & 2 Parcel 16 in the amount of \$2,935.00; and

WHEREAS, on March 22, 2016, the Authority approved Resolution 2016-44 Work Authorization 2 to the Professional Service Agreement with SAMES, Inc. to provide revised parcels 13P1, 13P2, 22, 26, 31, 39 and Salinas parcel for State Highway 365 Project in the amount of \$13,567.50 for a revised amount of \$16,502.50 for Work Authorizations 1 and 2. The maximum payable amount remains at \$25,000; and

WHEREAS, on April 26, 2016, the Authority approved Resolution 2016-58 for Work Authorization 3 to the professional service agreement with SAMES Engineering to provide modifications to Parcel(s) 5 Part 5-AQ and 5- Part 5-R; 7 and 15 for State Highway 365 in the amount of \$13,085.00; and

WHEREAS, on April 26, 2016, the Authority approved Resolution 2016-59 for Contract Amendment 1 to the professional service agreement with SAMES Engineering to increase the maximum payable amount for Work Authorization Number 3 in the amount of \$4,587.50; and

WHEREAS, on May 26, 2016, the Authority approved Resolution 2016-79 Work Authorization 4 to the professional service agreement with SAMES Engineering to provide Parcels 5 B, 3 6 B and 80 for State Highway 365 in the amount of \$5,085.00 whereas only \$4,060.00 were expended; and

WHEREAS, on June 28, 2016, the Authority approved Resolution 2016-81 Work Authorization 5 to the professional service agreement with SAMES Engineering to provide parcels 107- A, 13P2, 102, 20, 108, 110, 111, 112 and 113 for the 365 Tollway Project in the amount of \$22,325.00; and

WHEREAS, on June 28, 2016, the Authority approved Resolution 2016-82 Contract Amendment 2 to the professional service agreement with SAMES Engineering for Work Authorization Numbers 4 & 5 in the amount of \$26,385.00 for a revised increase of a maximum payable amount of \$55,972.50; and

WHEREAS, on July 26, 2016, the Authority approved Resolution 2016-97 for Work Authorization 3 Supplemental 1 to the professional service agreement with SAMES Engineering for a no-cost time extension for parcel revision to the 365 Tollway Project; and

WHEREAS, on July 26, 2016 the Authority approved Resolution 2016-98 for Work Authorization 6 to the professional service agreement with SAMES Engineering to provide parcels 7, 7B, and 9P2 for Segment 2 of the 365 Tollway Project in the amount of \$4,080.00; and

WHEREAS, on July 26, 2016, the Authority approved Resolution 2016-99 for Contract Amendment 3 to the professional service agreement with SAMES Engineering for Work Authorization 6 in the amount of \$4,080.00 for a revised increase of a maximum payable amount of \$60,052.50; and

WHEREAS, on August 23, 2016 the Authority approved Resolution 2016-105 for Work Authorization 7 to the professional service agreement with SAMES Engineering to provide right of way staking for Veterans Road and Hi-Line Road for utility relocations in the amount of \$5,650.00; and

WHEREAS, on August 23, 2016 the Authority approved Resolution 2016-106 for Contract Amendment 4 to the professional service agreement with SAMES Engineering for Work Authorization Numbers 7 in the amount of \$5,650.00 for a revised increase a maximum payable amount of \$65,720.50; and

WHEREAS, on September 27, 2016 the Authority approved Resolution 2016-112 Work Authorization 8 to the professional service agreement with SAMES Engineering to provide revisions to parcel 49 P1 in the amount of \$1,625.00; and

WHEREAS, on September 27, 2016 the Authority approved Resolution 2016-113 Work Authorization 9 to the professional service agreement with SAMES Engineering to provide construction monuments for the 365 Tollway Project in the amount of \$26,365.00; and

WHEREAS, on September 27, 2016 the Authority approved Resolution 2016-114 Contract Amendment 5 to the professional service agreement with SAMES Engineering to increase the maximum payable amount for Work Authorization Number 8 & 9 in the amount of \$27,990.00; and

WHEREAS, on November 1, 2016 the Authority approved Resolution 2016-123 Work Authorization 10 to the professional service agreement with SAMES Engineering to provide parcel sketches for corner clips at Steward Road & US 281/Military Highway as part of the Overpass/BSIF Connector for 365 Tollway Project in the amount of \$1,270.00; and

WHEREAS, on November 1, 2016 the Authority approved Resolution 2016-124 Contract Amendment 6 to the professional service agreement with SAMES Engineering to increase the maximum payable amount for Work Authorization Number 10 in the amount of \$1,270.00; and

WHEREAS, on November 15, 2016 the Authority approved Resolution 2016-125 Work Authorization 11 to the professional service agreement with SAMES Engineering to provide surveys for parcels 21, 22, 22C Lateral D and Pawlik tract as part of the 365 Tollway Project in the amount of \$12,030.00; and

WHEREAS, on November 15, 2016 the Authority approved Resolution 2016-126 Contract Amendment Number 7 to the Professional Service Agreement with SAMES Engineering to increase the maximum amount payable for Work Authorization 11 as part of the 365 Tollway Project in the amount of \$12,030.00; and

WHEREAS, on January 24, 2017 the Authority approved Resolution 2017-02 Work Authorization 12 to the professional service agreement with SAMES Engineering to update surveys 22D and 108 as part of the 365 Tollway Project in the amount of \$1,840.00; and

WHEREAS, on January 24, 2017 the Authority approved Resolution 2017-05 Work Authorization 13 to the professional service agreement with SAMES Engineering to update survey 20 and provide surveys for parcels OD2 & OD3 as part of the 365 Tollway Project in the amount of \$9,715.00; and

WHEREAS, on January 24, 2017 the Authority approved Resolution 2017-03 Contract Amendment 8 to the professional services agreement with SAMES Engineering to increase the maximum amount payable for Work Authorization 12 & 13 as part of the 365 Tollway Project in the amount of \$11,555.00; and

WHEREAS, on February 28, 2017 the Authority approved Resolution 2017-14 Work Authorization 14 to the professional service agreement with SAMES Engineering to provide parcel sketches for offsite drainage outfall parcels for the 365 Tollway Project in the amount of \$83,030.00; and

WHEREAS, on February 28, 2017 the Authority approved Resolution 2017-15 Work Authorization 15 to the professional service agreement with SAMES Engineering to provide subsurface utility engineering for utility relocation as part of the 365 Tollway Project in the amount of \$44,948.00; and

WHEREAS, on February 28, 2017 the Authority approved Resolution 2017-16 Contract Amendment 9 to the professional service agreement with SAMES Engineering for increase in maximum amount payable for Work Authorization Numbers 14 and 15 in the amount of \$127,978.00; and

WHEREAS, on March 28, 2017 the Authority Approved Resolution 2017-36 Supplemental Number 2 to Work Authorization Number 3 to the professional service agreement with SAMES Engineering for a no-cost time extension to provide surveys for Parcels 5, 5P and 15; and

WHEREAS, on March 28, 2017 the Authority Approved Resolution 2017-37 Supplemental Number 1 to Work Authorization Number 9 to the professional service agreement with SAMES Engineering for a no-cost time extension to provide construction control monuments; and

WHEREAS, on March 28, 2017 the Authority Approved Resolution 2017-38 to Work Authorization Number 16 to the professional service agreement with SAMES Engineering to provide a survey for parcel 36A as part of the 365 Tollway Project in the amount of \$3,230.00; and

WHEREAS, on March 28, 2017 the Authority approved Resolution 2017-39 Contract Amendment 10 to the professional service agreement with SAMES Engineering for increase in maximum amount payable for Work Authorization Number 16 in the amount of \$3,230.00; and

WHEREAS, on August 29, 2017 the Authority approved Resolution 2017-74 Approval of Work Authorization 15 – Supplemental 1 to the professional services agreement with SAMES Engineering for additional Subsurface Utility Engineering for the 365 Tollway Project in the amount of \$20,926.00; and

WHEREAS, on August 22, 2017 the Authority approved Resolution 2017-75 Contract Amendment 11 to the professional service agreement with SAMES Engineering for increase in maximum amount payable for Work Authorization Number 15 – Supplemental 1 in the amount of \$20,926.00; and

WHEREAS, on March 27, 2018 the Authority approved Resolution 2018-12 Approval of Work Authorization 3 - Supplemental 3 to the Professional Services Agreement with SAMES Inc. for a no cost-extension to invoice 100% of Parcel 5P5, HVI acquisition; and

WHEREAS, on March 27, 2018 the Authority approved Resolution 2018-13 Approval of Work Authorization 14 - Supplemental 1 to the Professional Services Agreement with SAMES Inc. for a no cost-extension for the outfall development; and

WHEREAS, on March 27, 2018 the Authority approved Resolution 2018-14 Approval of Work Authorization 17 with SAMES Inc. for the HCID2 parcel adjacent to Parcel 65P9 near Hi Line Road in the amount of \$2,080.00; and

WHEREAS, on March 27, 2018 the Authority approved Resolution 2018-15 Contract Amendment 12 to the professional service agreement with SAMES Engineering for increase in maximum amount payable for Work Authorization Number 17 in the amount of \$2,080.00; and

WHEREAS, on June 26, 2018 the Authority approved Resolution 2018-37 Contract Amendment 13 to the professional services agreement with SAMES Engineering for a no-cost time extension to provide survey services for the 365 Tollway and International Bridge Trade Corridor Projects; and

WHEREAS, on October 23, 2018 the Authority approved Resolution 2018-56 Work Authorization 14 Supplemental 2 to the professional services agreement with SAMES Engineering for Off-Site Outfalls/Irrigation Parcels for the 365 Toll Project in the amount of \$4,370.00; and

WHEREAS, on October 23, 2018 the Authority approved Resolution 2018-57 Contract Amendment 14 to the professional services agreement with SAMES Engineering to increase the maximum payable amount for Work Authorization 14 – Supplemental 2 in the amount of \$4,370.00; and

WHEREAS, on January 22, 2019 the Authority approved Resolution 2019-04 Work Authorization 18 to the professional services agreement with SAMES Engineering for I-Road parcels for the 365 Tollway Project in the amount of \$6,350.00; and

WHEREAS, on January 22, 2019 the Authority approved Resolution 2019-05 Contract Amendment 15 to the professional services agreement with SAMES Engineering to increase the maximum payable amount for Work Authorization 18 in the amount of \$6,350.00; and

WHEREAS, on March 23, 2021 the Authority approved Resolution 2021-06 Work Authorization 19 to the professional services agreement with SAMES Engineering for 365 Toll/HCID2 parcel updates for the 365 Tollway Project in the amount of \$1,180.00; and

WHEREAS, on March 23, 2021 the Authority approved Resolution 2021-07 Contract Amendment 16 to the professional services agreement with SAMES Engineering to increase the maximum payable amount for Work Authorization 19 in the amount of \$1,180.00; and

WHEREAS, on April 27, 2021 the Authority approve Resolution 2021-11 Supplemental Agreement 1 to Work Authorization 19 to the professional services agreement with SAMES Engineering for 365 Toll/HCID2 parcel updates for the 365 Tollway Project in the amount of \$2,330.00; and

WHEREAS, on April 27, 2021 the Authority approved Resolution 2021-12 Contract Amendment 17 to the professional services agreement with SAMES Engineering to increase the maximum payable amount for Supplemental Agreement 1 to Work Authorization 19 in the amount of \$2,330.00; and

WHEREAS, on May 26, 2021 the Authority approved Resolution 2021-16 Supplemental Agreement 2 to Work Authorization 19 to the professional services agreement with SAMES Engineering for 365 Toll/HCID2 parcel updates for the 365 Tollway Project in the amount of \$3,180.00. and

WHEREAS, on May 26, 2021 the Authority approved Resolution 2021-17 Contract Amendment 18 to the professional services agreement with SAMES Engineering to increase the maximum payable amount for Supplemental Agreement 2 to Work Authorization 19 in the amount of \$3,180.00; and

WHEREAS, on June 22, 2021 the Authority approved Resolution 2021-19 Supplemental Agreement 3 to Work Authorization 19 to the professional services agreement with SAMES Engineering for re-issuing HCDD #1 Outfall parcels updates for the 365 Tollway Project in the amount of \$3,595.00; and

WHEREAS, on June 22, 2021 the Authority finds it necessary to approve Resolution 2021-20 Contract Amendment 19 to the professional services agreement with SAMES Engineering to increase the maximum payable amount for Supplemental Agreement 3 to Work Authorization 19 in the amount of \$3,595.00; and

WHEREAS, on November 23, 2021 the Authority approved Resolution 2021-67 Contract Amendment 20 to the professional services agreement with SAMES Engineering for a no-cost time extension to provide survey services for the 365 Tollway and International Bridge Trade Corridor projects; and

WHEREAS, on March 28, 2023 the Authority approved Resolution 2023-19 Work Authorization 20 to the Professional Services Agreement with SAMES Engineering for surveying services for the "X" Parcels claimed by Hidalgo County Irrigation District Number 2 as part of the 365 Tollway Project in the amount of \$56,245.00; and

WHEREAS, on March 28, 2023 the Authority approved Resolution 2023-20 Work Authorization 21 to the Professional Services Agreement with SAMES Engineering for surveying services for a corner clip to accommodate utility relocation along Thomas and I Road [Veteran's] as part of the 365 Tollway Project in the amount of \$1,800.00; and

WHEREAS, on November 28, 2023 the Authority approved Resolution 2023-47 Supplemental No. 1 to Work Authorization 20 to the Professional Services Agreement with SAMES Engineering for surveying services for additional "X" Parcels claimed by Hidalgo County Irrigation District Number 2 as part of the 365 Tollway Project in the amount of \$15,715.00; and

WHEREAS, on February 27, 2024 the Authority approved Resolution 2024-12 Supplemental No. 1 to Work Authorization 21 to the Professional Services Agreement with SAMES Engineering for surveying services for additional "X" Parcels claimed by Hidalgo County Irrigation District Number 2 as part of the 365 Tollway Project in the amount of \$19,845.00; and

WHEREAS, the Authority finds it necessary to approve Resolution 2024-29 Supplemental No. 2 to Work Authorization 21 to the Professional Services Agreement with SAMES Engineering for a no-cost time extension for surveying services for additional "X" Parcels claimed by Hidalgo County Irrigation District Number 2 as part of the 365 Tollway Project.

NOW THEREFORE, BE IT RESOLVED, BY THE BOARD OF DIRECTORS OF THE HIDALGO COUNTY REGIONAL MOBILITY AUTHORITY THAT:

Section 1. The recital clauses are incorporated in the text of this Resolution as if fully restated.

Section 2. The Board hereby approves Resolution 2023-47 for Supplemental No. 1 to Work Authorization 20 to the professional service agreement with SAMES Engineering to provide survey services for the 365 Tollway hereto attached as Exhibit A.

Section 3. The Board authorizes the Executive Director to execute the Supplemental No. 1 to Work Authorization 20 to the Professional Services Agreement for Surveying Services with SAMES Engineering as approved.

PASSED AND APPROVED AS TO BE EFFECTIVE IMMEDIATELY BY THE BOARD OF DIRECTORS OF THE HIDALGO COUNTY REGIONAL MOBILITY AUTHORITY AT A REGULAR MEETING, duly posted and noticed, on the 25th day of June 2024, at which meeting a quorum was present.

S. David Deanda, Jr., Chairman

Juan Carlos Del Ángel, Secretary/Treasurer

Exhibit A

Supplemental No. 2 to Work
Authorization Number 21
to
Professional Service Agreement
with SAMES, Inc.
for
Surveying Services

**SUPPLEMENTAL WORK AUTHORIZATION NO. 2 TO
WORK AUTHORIZATION NO. 21 AGREEMENT FOR
SURVEYING SERVICES**

THIS SUPPLEMENTAL WORK AUTHORIZATION is made pursuant to the terms and conditions of “Article V of that certain Professional Services Agreement for Surveying Services” hereinafter identified as the “Agreement,” entered into by and between the Hidalgo County Regional Mobility Authority (Authority), and SAMES, Inc. (the Surveyor).

The following terms and conditions of Work Authorization No. 21 are hereby amended as follows:

Part IV: Work Authorization No. 21 shall now terminate on December 31, 2025 and a revised Work Schedule will be supplied to document the revised date of work activity.

IN WITNESS WHEREOF, this Supplemental Work Authorization is executed in duplicate counterparts and hereby accepted and acknowledged below.

THE SURVEYOR

(Signature)
Samuel Maldonado, P.E., RPLS

(Printed Name)
Principal

(Title)

(Date)

THE AUTHORITY

(Signature)
Pilar Rodriguez, P.E.

(Printed Name)
Executive Director

(Title)

(Date)

Item 3C

HIDALGO COUNTY REGIONAL MOBILITY AUTHORITY

AGENDA RECOMMENDATION FORM

BOARD OF DIRECTORS	<u> X </u>	AGENDA ITEM	<u> 3C </u>
PLANNING COMMITTEE	<u> </u>	DATE SUBMITTED	<u> 06/18/24 </u>
FINANCE COMMITTEE	<u> </u>	MEETING DATE	<u> 06/25/24 </u>
TECHNICAL COMMITTEE	<u> </u>		

1. Agenda Item: **RESOLUTION 2024-30 – CONSIDERATION AND APPROVAL OF SUPPLEMENTAL NUMBER 3 TO WORK AUTHORIZATION NUMBER 8 WITH HDR ENGINEERING, INC. TO PROVIDE CONSTRUCTION INSPECTION SERVICES FOR THE 365 TOLLWAY CONSTRUCTION PROJECT.**

2. Nature of Request: (Brief Overview) Attachments: X Yes No

Consideration and Approval of SA No.3 WA 8 to the PSA with HDR Engineering, Inc. to provide Construction Inspection Services for the 365 Tollway Project.

3. Policy Implication: Board Policy, Local Government Code, Texas Government Code, Texas Transportation Code, TxDOT Policy

4. Budgeted: X Yes No N/A

5. Staff Recommendation: **Motion to Approve Resolution 2024-30 – Consideration and Approval Supplemental Number 3 to Work Authorization Number 8 with HDR Engineering Inc. to provide Construction Inspection services for the 365 Tollway Construction Project, as presented.**

6. Program Manager’s Recommendation: Approved Disapproved X None

7. Planning Committee’s Recommendation: Approved Disapproved X None

8. Board Attorney’s Recommendation: Approved Disapproved X None

9. Chief Auditor’s Recommendation: Approved Disapproved X None

10. Chief Financial Officer’s Recommendation: Approved Disapproved X None

11. Chief Development Engineer’s Recommendation: Approved Disapproved X None

12. Chief Construction Engineer’s Recommendation: X Approved Disapproved None

13. Executive Director’s Recommendation: X Approved Disapproved None



- CMT Services
- Environmental
- Engineering **HDR Engineering, Inc.**
- Geo-Technical
- Surveying

WORK AUTHORIZATION SUMMARY

RESOLUTION 2024-30

Work Authorization # 8 Supplemental # 3

Amount \$ 1,009,480.30

Approved Work Authorizations

Resolution No.	Description	Amount
2020-32	WA No. 1-Amended & Restated	\$ 301,579.58
2020-33	WA No. 2-Construction Contract Letting Support	\$ 125,723.03
2020-35	SA 1 to WA No. 2-Construction Contract Letting	\$ 93,284.63
2020-36	WA No. 3-365 Toll Integration Contract Letting	\$ 299,785.36
2021-21	WA 4 IBTC Final Schematic Environmental	\$ 197,746.02
Subtotal from Cont. Page		\$ 4,473,210.74
Total Approved WA		\$ 5,491,329.36
Proposed Work Authorization and/or Supplemental		
2024-30	WA8 SA3 Const. Inspection Support 365 Toll	\$ 1,009,480.30

Contract Amount

Consideration and approval of Work Authorization 8 Supplemental Number 3 to the Professional Service Agreement with HDR Engineering for to provide Construction Inspection Services for the 365 Tollway Project.

Staff is recommending approval of this request in the amount of \$ 1,009,480.30
Proposed total approved WA and/or Supplementals \$ 6,500,809.66

R. Navarro IV, Cons Eng
Requested By:

Resolution No.	Description	Amount
2021-51	WA 5 Support Wetland Mitigation Site	\$ 310,039.40
2021-74	WA No. 6 - 365 Toll VE -Change Proposal	\$ 79,429.57
2022-02	WA No. 1 Supplemental 1 No Cost Time Ext.	\$ 0.00
2022-03	WA No. 2 Supplemental 2 No Cost Time Ext.	\$ 0.00
2022-04	WA No. 3 Supplemental 1 No Cost Time Ext.	\$ 0.00
2022-11	WA No. 7 365 Toll VECP Design QA	\$ 119,970.68
2022-22	WA No. 8 Const. Mgt. Support 365 Toll Project	\$ 1,244,594.55
2022-50	WA No. 2 Supplemental 4	\$ 0.00
2022-51	WA No. 3 Supplemental 2	\$ 88,206.93
2022-52	WA No. 4 Supplemental 1	\$ 85,846.48
2022-65	WA 5 Supplemental 1 No Cost Time Ext.	\$ 0.00
2022-66	WA 7 Supplemental 1 No Cost Time Ext.	\$ 0.00
2023-13	SA 3 WA No. 3 - TSI Procurement Support	\$ 289,198.08
2023-25	WA 4 SA 2 No Cost Time Extension	\$ 0.00
2023-26	WA8 SA1 Add Aquadic Life Relo, Wetland Bou	\$ 227,058.56
2023-27	WA 9 - Next Phase of TSI Coordination	\$ 1,427,870.83
2023-35	WA No. 3 SA 4 No-Cost Time Extension	\$ 0.00
2023-44	WA8 SA2 Const. Mgt. Support 365 Toll Project	\$ 600,995.66

Subtotal \$ 4,473,210.74

HIDALGO COUNTY REGIONAL MOBILITY AUTHORITY

BOARD RESOLUTION No. 2024-30

RESOLUTION 2024-30 – CONSIDERATION AND APPROVAL OF WORK AUTHORIZATION 8 SUPPLEMENTAL NUMBER 3 TO THE PROFESSIONAL SERVICE AGREEMENT WITH HDR ENGINEERING FOR TO PROVIDE CONSTRUCTION INSPECTION SERVICES FOR THE 365 TOLLWAY CONSTRUCTION PROJECT

THIS RESOLUTION is adopted this 25th day of June 2024, by the Board of Directors of the Hidalgo County Regional Mobility Authority at a regular meeting.

WHEREAS, the Hidalgo County Regional Mobility Authority (the “Authority”), acting through its Board of Directors (the “Board”), is a regional mobility authority created pursuant to Chapter 370, Texas Transportation Code, as amended (the “Act”);

WHEREAS, the Authority is authorized by the Act to address mobility issues in and around Hidalgo County;

WHEREAS, on February 22, 2012 the Authority approved Resolution 2012-04, which created the Technical Committee, comprised of senior level engineers and professional from various communities and agencies in the jurisdiction of the Authority, to serve to advise the Board on procurement and consultant work products; and

WHEREAS, Resolution 2012-04 also authorized the Executive Committee to determine the size, structure and scope of the Technical Committee, identify candidates and issue requests for participation; and

WHEREAS, February 27, 2018, the Authority approved Resolution 2018-07 which for the procurement of Professional Engineering Services for a General Engineering Consultant for the Hidalgo County Loop System including, but not limited to Advance Project Development and Construction Management Support; and

WHEREAS, the Technical Committee has rated and ranked the Statements of Qualifications for the General Engineering Consultant Services and recommends interviews be dispensed with and that staff be authorized to negotiate with HDR Engineering, Inc.;

WHEREAS, on February 26, 2019 the Authority approved Resolution 2019-01 Approval of a Professional Service Agreement with HDR Engineering, Inc. to provide General Consultant Services for the Hidalgo County Loop System of the Hidalgo County Regional Mobility Authority in the amount of \$488,657.91; and

WHEREAS, on March 5, 2019 the Authority approved approve Resolution 2019-02 Approval of a Work Authorization 1 to the Professional Service Agreement with HDR

Engineering, Inc. Project Management for the 365 Tollway Project in the amount of \$171,350.84; however, no notice to proceed was issued; and

WHEREAS, on November 17, 2020 in order to reflect a change in the planned series of tasks relating to a changed project letting schedule, the Board found it to be in the best interest of the Authority to approve Resolution 2020-32 Approval of Amended and Restated Work Authorization 1 to the Professional Service Agreement with HDR Engineering, Inc. for General Engineering Consulting Services for the 365 Tollway Program Management Support in the amount of \$301,579.58; and

WHEREAS, on November 17, 2020 the Authority approved Resolution 2020-33 Approval of a Work Authorization 2 to the Professional Service Agreement with HDR Engineering, Inc. for General Engineering Consultant Services for the 365 Tollway Roadway Construction Contract Letting Support in the amount of \$125,723.03; and

WHEREAS, on December 15, 2020 the Authority approved Resolution 2020-35 Approval of Supplemental Agreement 1 to Work Authorization 2 to the Professional Service Agreement with HDR Engineering, Inc. for General Engineering Consultant Services for the 365 Tollway Roadway Construction Contract Letting Support in the amount of \$93,284.63; and

WHEREAS, on December 15, 2020 the Authority approved Resolution 2020-36 Approval of a Work Authorization 3 to the Professional Service Agreement with HDR Engineering, Inc. for General Engineering Consultant Services for the 365 Tollway Integration Contract Letting Support in the amount of \$299,785.36; and

WHEREAS, on December 15, 2020 the Authority approved Resolution 2020-37 Approval of Contract Amendment 1 to the Professional Service Agreement with HDR to increase the maximum payable amount from \$488,657.91 to \$820,372.60 for a total increase of \$331,714.69 due to additional scope and effort outlined in Supplemental Agreement 1 to Work Authorization No. 2 and Work Authorization No. 3; and

WHEREAS, on June 22, 2021 the Authority approved Resolution 2021-21 Approval of a Work Authorization 4 to the Professional Service Agreement with HDR Engineering, Inc. for IBTC final schematic Support for the Environmental Clearance in the amount of \$197,746.02; and

WHEREAS, on June 22, 2021 the Authority approved Resolution 2021-22 Approval of Contract Amendment 2 to the Professional Service Agreement with HDR to increase the maximum payable amount from \$820,372.60 to \$1,018,118.62 for a total increase of \$197,746.02 for Work Authorization No. 4; and

WHEREAS, on December 20, 2021 the Authority approved Resolution 2021-51 Approval of a Work Authorization 5 to the Professional Service Agreement with HDR Engineering, Inc. for engineering support for the design and construction of the 365 Tollway Wetland Mitigation site in the amount of \$310,039.40; and

WHEREAS, on December 20, 2021 the Authority approved Resolution 2021-74 Consideration and Approval of Work Authorization 6 with HDR Engineering, Inc. for engineering support for review of the 365 Tollway Value Engineering Change Proposals in the amount of \$79,429.57; and

WHEREAS, on December 20, 2021 the Authority approved Resolution 2021-52 Approval of Contract Amendment 3 to the Professional Service Agreement with HDR to increase the maximum payable amount from \$1,018,118.62 to \$1,407,587.59 for a total increase of \$389,468.97 for Work Authorization No. 5 & Work Authorization No. 6; and

WHEREAS, on January 25, 2022 the Authority approved Resolution 2022-02 Consideration and Approval of Work Authorization 1 Supplemental 1 to the Professional Service Agreement with HDR Engineering, Inc. for a no-cost time extension for general engineering consulting services to the Hidalgo County Regional Mobility Authority; and

WHEREAS, on January 25, 2022 the Authority approved Resolution 2022-03 Consideration and Approval of Work Authorization 2 Supplemental 2 to the Professional Service Agreement with HDR Engineering, Inc. for a no-cost time extension for general engineering consulting services to the Hidalgo County Regional Mobility Authority; and

WHEREAS, on January 25, 2022 the authority approved Resolution 2022-04 Consideration and Approval of Work Authorization 3 Supplemental 1 to the Professional Service Agreement with HDR Engineering, Inc. for a no-cost time extension for general engineering consulting services to the Hidalgo County Regional Mobility Authority; and

WHEREAS, on February 22, 2022 the Authority approved Resolution 2022-11 - Consideration and Approval of Work Authorization 7 with HDR Engineering, Inc. for engineering services for the review for the updated design initiated under the 365 Tollway Value Engineering Change Proposal process in the amount of \$119,970.68; and

WHEREAS, on March 22, 2022 the Authority approved Resolution 2022-22 – Consideration and Approval of Work Authorization Number 8 with HDR Engineering, Inc. for general engineering services for construction management of the 365 Tollway in the amount of \$1,244,594.55; and

WHEREAS, on April 26, 2022 the Authority through Resolution 2022-32 approved Work Authorization 2 Supplemental 3 to the Professional Services Agreement with HDR Engineering, Inc. for a no-cost time extension for general engineering consulting services to the Hidalgo County Regional Mobility Authority through July 31, 2022; and

WHEREAS, on August 23, 2022 the Authority approved Resolution 2022-53 approval of Contract Amendment 6 to the professional service agreement with HDR Engineering to increase the maximum payable amount for supplemental number 2 to work authorization number 3 to \$88,206.93 and supplemental number 1 to work authorization number 4 to \$85,846.48 with HDR Engineering, Inc.; and

WHEREAS, on February 28, 2023 the Authority approved Resolution 2023-08 approving Contract Amendment Number 7 to the Professional Service Agreement with HDR Engineering for revised hourly rates for General Engineering Consultant and Program Manager Services for the 365 Tollway and IBTC Projects hereto attached as Exhibit A.; and

WHEREAS, on March 14, 2023 the Authority approved Resolution 2023-13 approving of Supplemental Number 3 to Work Authorization Number 3 to the Professional Service Agreement with HDR Engineering in the amount of \$289,198.08 to provide Toll System Integrator procurement support and an update of the Maintenance & Operation Financial Model for the 365 Tollway Project; and

WHEREAS, on June 27, 2023 the Authority approved Resolution 2023-27 approving of Work Authorization Number 9 to the Professional Service Agreement with HDR Engineering in the amount of 1,427,870.83 for the next phase of TSI coordination and implementation for the 365 Tollway; and

WHEREAS, on September 26, 2023 the Authority approved Resolution 2023-35 approving of Work Authorization Number 3 Supplemental Number 4 to the Professional Service Agreement with HDR Engineering for a no-cost time extension for General Engineering Consulting Services to the Hidalgo County Regional Mobility Authority; and

WHEREAS, on October 24, 2023 the Authority approved Resolution 2023-44 approving of Work Authorization Number 8 Supplemental Number 2 to the Professional Service Agreement with HDR Engineering general engineering services for construction management of the 365 Tollway in the amount of \$600,995.66; and

WHEREAS, on December 12, 2023 the Authority approved Resolution 2023-53 approving of Work Authorization Number 5 Supplemental Number 2 to the Professional Service Agreement with HDR Engineering for a no-cost time extension for engineering support for the design and construction of the 365 Tollway Wetland Mitigation site; and

WHEREAS, the Authority finds it necessary to approve Resolution 2024-30 approving of Work Authorization Number 8 Supplemental Number 3 to the Professional Service Agreement with HDR Engineering to provide construction inspection services for the 365 Tollway construction project in the amount of \$1,009,480.30.

NOW THEREFORE, BE IT RESOLVED, BY THE BOARD OF DIRECTORS OF THE HIDALGO COUNTY REGIONAL MOBILITY AUTHORITY THAT:

- Section 1. The recital clauses are incorporated in the text of this Resolution as if fully restated.
- Section 2. The Board hereby approves of Work Authorization Number 8 Supplemental Number 3 to the Professional Service Agreement with HDR Engineering for general engineering services, hereto attached as Exhibit A.
- Section 3. The Board authorizes the Executive Director to execute Work Authorization 8 Supplemental 3 to the Professional Services Agreement with HDR.

PASSED AND APPROVED AS TO BE EFFECTIVE IMMEDIATELY BY THE BOARD OF DIRECTORS OF THE HIDALGO COUNTY REGIONAL MOBILITY AUTHORITY AT A REGULAR MEETING, duly posted and noticed, on the 25th day of June 2024, at which meeting a quorum was present.

S. David Deanda, Jr., Chairman

Juan Carlos Del Angel, Secretary/Treasurer

EXHIBIT A

WORK AUTHORIZATION & SUPPLEMENTAL
NUMBER 3
TO THE PROFESSIONAL SERVICE AGREEMENT
FOR
GENERAL ENGINEERING CONSULTANT SERVICES
BETWEEN
THE HIDALGO COUNTY REGIONAL MOBILITY AUTHORITY
AND
HDR ENGINEERING, INC.

ATTACHMENT D-2

**SUPPLEMENTAL WORK AUTHORIZATION NO. 3
TO WORK AUTHORIZATION NO. 8
AGREEMENT FOR GENERAL ENGINEERING CONSULTING SERVICES**

THIS SUPPLEMENTAL WORK AUTHORIZATION is made pursuant to the terms and conditions of "Article V of that certain Professional Services Agreement for General Engineering Consulting Services" hereinafter identified as the "Agreement," entered into by and between the Hidalgo County Regional Mobility Authority (Authority), and HDR Engineering Inc. (the GEC).

The following terms and conditions of Work Authorization No. 8 are hereby amended as follows:

PART I. The GEC services from Exhibit B Work Authorization No. 8 remain in effect. This Supplemental Agreement provides additional funds for the GEC to continue providing these services.

PART II. The maximum amount payable under this Supplemental Agreement is \$1,009,480.30 and the method of payment is Specified Rate Basis as set forth in Attachment E of the Agreement. This amount is based upon fees set forth in attachment E, Fee Schedule of the Agreement and the GEC's estimated Supplemental Agreement costs included in Exhibit D, Fee Schedule, which is attached and made a part of this Supplemental Agreement.

PART IV. This Supplemental Agreement shall become effective on the date of final acceptance of the parties hereto and shall terminate on December 31, 2024, unless extended by a supplemental Work Authorization as provided in Attachment A, Section 1.

This Supplemental Work Authorization shall become effective on the date of final execution of the parties hereto. All other terms and conditions of Work Authorization No. 8 not hereby amended are to remain in full force and effect.

IN WITNESS WHEREOF, this Supplemental Work Authorization is executed in duplicate counterparts and hereby accepted and acknowledged below.

THE GEC

THE AUTHORITY

(Signature)

(Printed Name)

(Title)

(Date)

(Signature)

(Printed Name)

(Title)

(Date)

LIST OF EXHIBITS

Exhibit B	Services to be provided by the GEC
Exhibit C	Work Schedule
Exhibit D	Fee Schedule/Budget
Exhibit H-2	Sub Provider Monitoring System Commitment Agreement

EXHIBIT B
SERVICES TO BE PROVIDED BY THE ENGINEER

1. General

The purpose of this supplemental contract is to amend GEC services executed under the original work authorization #8 to continue assisting the Hidalgo County Regional Mobility Authority (HCRMA)(hereinafter referred to as the “Authority”) with construction phase tasks for the 365 Toll project (hereinafter referred to as the “Project”). Additional services appended by this supplemental contract are identified under each task. An outline for the task categories to provide these services is as follows:

2. Project Management / Administration
3. Authority Construction Phase Tasks – defined as tasks led and championed by the Authority in which the GEC serves as a partner who reviews and provides feedback on Authority composed documents.
4. GEC Construction Phase Tasks – defined as tasks led and championed by the GEC in which the Authority, as a partner, reviews and provides feedback on GEC composed documents.

2. Project Management / Administration

There are no changes or additions to the original services for this task.

3. Authority Construction Phase Tasks

The Authority is providing the core staff for construction record keeping, reporting, and field inspection of the Project. The Authority has requested participation of GEC staff to support field reporting and field inspection. The GEC staff will perform the following:

- a. Construction Manager / Management
- b. Construction staffing / logistics
- c. Participate in safety or technical training
- d. Support material testing management / QAP documentation – Coordination and management with material testing firms
- e. Participate in construction progress meetings – weekly
- f. Support response to Contractor Requests for Information (RFI)
- g. Daily Work Report Diary
- h. Support daily summary of contractor work items performed
- i. Support monthly summary of contractor work items performed
- j. Assist with day / nighttime barricade inspections and reporting
- k. Assist with material on hand monitoring / documentation
- l. Monthly Pay Estimates / Finance Summary – GEC will review and provide feedback including recommendations for drawdown requests.
- m. Assist in reviewing Contractor claims

n. Assist in reviewing Contractor Change Orders

GEC will not be responsible for the means, methods, techniques, sequences, or procedures of construction selected by the Contractor(s) or the safety precautions and programs incident to the work of the Contractor(s). The GEC's effort will be directed toward providing a greater degree of confidence for the Authority that the completed work of Contractor(s) will conform to the Contract Documents, but the GEC will not be responsible for the failure of Contractor(s) to perform the work in accordance with the Contract Documents. During on-site observations the GEC shall keep the Authority informed of the progress of the work and shall endeavor to guard the Authority against defects and deficiencies in such work and may disapprove or reject work failing to conform to the Contract Documents.

The GEC is estimating a level of effort for providing on-call services for the above tasks which can be found in Exhibit D of this work authorization.

4. GEC Construction Phase Tasks

There are no changes or additions to the original services for this task.

Exhibit C

Proposed Work Schedule

365 Toll Construction Phase

Task 1

Project Management / Administration

7/1/2024 – 12/31/2024

Task 2

Authority Construction Ph Tasks

7/1/2024 – 12/31/2024

Task 3

GEC Construction Ph Tasks

7/1/2024 – 12/31/2024

Task 4

SW3P & Archaeological Monitoring

7/1/2024 – 12/31/2024

Exhibit D

Prime Provider: HDR Engineering, Inc.
 Subconsultant: Melden and Hunt
 Work Authorization: 08

	365 Toll Const Phase		Total by Firm	% by Firm
	Labor	ODE		
HDR	\$822,330.30	\$187,150.00	\$1,009,480.30	100%
<blank>	\$0.00	\$0.00	\$0.00	0%
<blank>	\$0.00	\$0.00	\$0.00	0%
<blank>			\$0.00	0%
<blank>			\$0.00	0%
<blank>			\$0.00	0%
<blank>			\$0.00	0%
<blank>			\$0.00	0%
Sub-Total by Task	\$822,330.30	\$187,150.00	Total WA	100%
Total by Task	\$1,009,480.30		\$1,009,480.30	

Prime Provider: HDR Engineering, Inc.
 Subconsultant: N/A
 Work Authorization: 08

Legend: recurring every X months = ~Xmos

Assume 18 months of construction (June 2024 - Jan 2026)

SA 3 to WA 8

Labor Categories	Project Manager	Deputy Project Manager	Sr Technical Advisor	Senior ITS Engineer	Senior Engineer	Project Engineer	Traffic Engineer II	Senior Geotech Engineer	Geotech Engineer	Archaeologist IV	Senior Environmental Scientist	Transportation Planner III	Senior Arch / Principal Inv.	Senior Utility Coord	Chief Inspector	Construction Manager	Const Inspector III	Senior Engineer Tech	Scheduler	Project Controller	Accounting	Admin III	Total Task Hours	Line Item Fee
Negotiated Rate	\$257.40	\$353.57	\$325.28	\$254.57	\$226.28	\$200.83	\$169.71	\$240.42	\$141.43	\$176.78	\$175.37	\$169.71	\$212.14	\$198.00	\$147.08	\$189.51	\$127.28	\$155.57	\$161.23	\$148.50	\$115.69	\$90.51		
DESCRIPTION OF TASKS/DETAILS																								
Task 001 - Project Management / Administration																							0	\$0.00
Monthly progress rpts/invoices/finance monitoring (6 mos)	3																			6	3	3	15	\$2,281.80
Work Authorization schedule (develop/monitor) (6 mos)																				1.5		1.5	3	\$358.52
Contractual document control (6 mos)																				12		24	36	\$3,954.24
General Support (6 mos)	24	24	12	12			18	18												12			120	\$30,785.82
Task 002 - Authority Const Ph Tasks																							0	\$0.00
Const Inspection (Assume avg 2 ppl @ 240 hr/mo for 6 months)											720				1440		1440						3600	\$521,344.80
-Const Inspection (Assume avg 2 ppl @ 160 hr/mo for 4 months)																							0	\$0.00
-Const Inspection (Assume avg 1 ppl @ 160 hr/mo for 4 months)																							0	\$0.00
Agency Coordination (TxDOT, IBWC, DDs, IDs, Cities)	18	24	8			16		6	8			16								12			108	\$26,005.72
Contractor Correspondence (claims, schedule, stop work, etc.)	48	24	24			16	48	12				16								12			200	\$47,389.36
Utility Coordination Support	12					16														12			40	\$8,084.08
Weekly meetings (HCRMA-HDR)	24	24		24		72	24													24		24	216	\$45,042.00
Task 003 - GEC Const Ph Tasks																							0	\$0.00
Review Contractor submittals (assume avg. 2ppl @ 16hr/mo for 6 mos)	4		8	96			96													18			222	\$47,035.72
Review Contractor submittals (assume avg. 1ppl @ 16hr/mo for 8 mos)																							0	\$0.00
Quarterly construction reports	1	4																		4			9	\$2,265.88
Monthly as-built tracking / final as-builts																							0	\$0.00
Review of Contractor's schedule							4												8				12	\$1,968.68
Contractor RFIs	8		16	48	30		48	18															168	\$38,745.08
SW3P and Archeological monitoring							6			240													246	\$43,445.46
Progress meetings (6 mos biwkly)	6						6			6													18	\$3,623.34
																							0	\$0.00
																							0	\$0.00
Labor Hours Total	148	100	68	180	30	120	250	54	8	246	720	32	0	0	1440	0	1440	0	8	113.5	3	52.5	5013	hours check
Labor Cost Total	\$38,095.20	\$35,357.00	\$22,119.04	\$45,822.60	\$6,788.40	\$24,099.60	\$42,427.50	\$12,982.68	\$1,131.44	\$43,487.88	\$126,266.40	\$5,430.72	\$0.00	\$0.00	\$211,795.20	\$0.00	\$183,283.20	\$0.00	\$1,289.84	\$16,854.75	\$347.07	\$4,751.78	\$822,330.30	cost check
% Staff Distribution	3%	2%	1%	4%	1%	2%	5%	1%	0%	5%	14%	1%	0%	0%	29%	0%	29%	0%	0%	2%	0%	1%	100%	

Prime Provider: HDR Engineering, Inc.
Subconsultant:
Work Authorization: 08

Legend: Current State Rate = CSR, Actual Cost = AC, Fixed = F, Max = M

OTHER DIRECT EXPENSE	UNIT	MAX RATE BASIS	FIXED / MAX	ODE RATE	TOTAL FOR WA08	Sub-Total per ODE
Lodging/Hotel - Taxes and Fees	day/person	n/a	M	\$32.00	580	\$18,560.00
Lodging/Hotel (Taxes/fees not included)	day/person	CSR	M	\$94.00	580	\$54,520.00
Meals (Excluding alcohol & tips) (Overnight stay required)	Day/person	CSR	M	\$55.00	580	\$31,900.00
Mileage	mile	CSR	F	\$0.585		\$0.00
Rental Car Fuel	gallon	n/a	M	\$3.75	1032	\$3,870.00
Rental Car (Includes taxes and fees; Insurance costs will not be reimbursed)	day	n/a	M	\$75.00	1044	\$78,300.00
Air Travel - In State - Short Notice (Coach)	Rd Trip/person	n/a	M	\$580.00		\$0.00
Air Travel - In State - 2+ Wks Notice (Coach)	Rd Trip/person	n/a	M	\$450.00		\$0.00
Air Travel - Out of State - 2+ Wks Notice (Coach)	Rd Trip/person	n/a	M	\$600.00		\$0.00
Air Travel - Out of State - Short Notice (Coach)	Rd Trip/person	n/a	M	\$900.00		\$0.00
Oversize, special handling or extra baggage airline fees	each	n/a	M	\$45.00		\$0.00
Taxi/Cab fare	each/person	n/a	M	\$30.00		\$0.00
Parking	day	n/a	M	\$20.00		\$0.00
Toll Charges	each	n/a	M	\$10.00		\$0.00
Standard Postage	letter	CSR	F	\$0.47		\$0.00
Certified Letter Return Receipt	each	CSR	F	\$6.20		\$0.00
Overnight Mail - letter size	each	CSR	M	\$22.00		\$0.00
Overnight Mail - oversized box	each	CSR	M	\$85.00		\$0.00
Courier Services	each	n/a	M	\$28.00		\$0.00
Photocopies B/W (11" X 17")	each	n/a	F	\$0.25		\$0.00
Photocopies B/W (8 1/2" X 11")	Each	n/a	F	\$0.12		\$0.00
Photocopies Color (11" X 17")	each	n/a	F	\$1.50		\$0.00
Photocopies Color (8 1/2" X 11")	each	n/a	M	\$0.85		\$0.00
Digital Ortho Plotting	sheet	n/a	M	\$1.25		\$0.00
Plots (B/W on Bond)	per sq. ft.	n/a	M	\$0.50		\$0.00
Plots (Color on Bond)	per sq. ft.	n/a	F	\$1.00		\$0.00
Plots (Color on Photographic Paper)	per sq. ft.	n/a	F	\$4.00		\$0.00
Color Graphics on Foam Board	square foot	n/a	F	\$5.00		\$0.00
Presentation Boards 30" X 40" Color Mounted	each	n/a	M	\$125.00		\$0.00
Report Printing	each	n/a	M	\$65.00		\$0.00
Report Binding and tabbing	each	n/a	M	\$8.00		\$0.00
Notebooks	each	n/a	M	\$9.00		\$0.00
Reproduction of CD/DVD	each	n/a	M	\$5.00		\$0.00
CDs	each	n/a	F	\$1.75		\$0.00
4" X 6" Digital Color Print	picture	n/a	F	\$0.25		\$0.00
Tx Parks & Wildlife Data Request Fees	each	n/a	M	\$50.00		\$0.00
Hazardous Materials Database Search	per search	n/a	M	\$350.00		\$0.00
Noise Meter Rental	per project	n/a	M	\$150.00		\$0.00
Environmental Database Search	per project	n/a	M	\$1,100.00		\$0.00
Environmental Field Supplies (lathes, stakes, flagging, spray paint, etc.)	day	n/a	M	\$65.00		\$0.00
Curator (Drawer & TX Archaeological Research Lab for artifacts & report)	per project	n/a	F	\$1,350.00		\$0.00
Newspaper Advertisement	per publication	n/a	M	\$1,650.00		\$0.00
Court Reporter	page	n/a	M	\$10.00		\$0.00
Court Reporter (Public Meetings, Hearings & Transcription)	day	n/a	M	\$500.00		\$0.00
Translator (English to Spanish, other language as appropriate, or Sign Language) for Public Involvement	event	n/a	F	\$500.00		\$0.00
Translator (English to Spanish, other language as appropriate, or Sign Language)	hour	n/a	M	\$100.00		\$0.00
Custodian for Public Involvement	hour/custodian	n/a	M	\$35.00		\$0.00
Sound Technician for Public Involvement	event	n/a	M	\$1,000.00		\$0.00
Law Enforcement/Uniform Officer (without vehicle)	per hr	n/a	M	\$45.00		\$0.00
				Total ODE Cost	\$187,150.00	\$187,150.00

Prime Provider: HDR Engineering, Inc.
 Subconsultant:
 Work Authorization: 08

Legend: Current State Rate = CSR, Actual Cost = AC, Fixed = F, Max = M

OTHER DIRECT EXPENSE	UNIT	MAX RATE BASIS	FIXED / MAX	ODE RATE	TOTAL FOR WA08	Sub-Total per ODE
Mileage (Tasks 1-3, 250miles/wk,~16wks)(Task 4, 250miles/wk,~197wks)	mile	CSR	F	\$0.585	0	\$0.00
				Total ODE Cost	\$0.00	\$0.00

THIS ITEM WILL BE
SENT UNDER
SEPERATE COVER

This Page
Intentionally
Left Blank

Item 3D

HIDALGO COUNTY REGIONAL MOBILITY AUTHORITY

AGENDA RECOMMENDATION FORM

BOARD OF DIRECTORS	<u> X </u>	AGENDA ITEM	<u> 3D </u>
PLANNING COMMITTEE	<u> </u>	DATE SUBMITTED	<u> 06/18/24 </u>
FINANCE COMMITTEE	<u> </u>	MEETING DATE	<u> 06/25/24 </u>
TECHNICAL COMMITTEE	<u> </u>		

1. Agenda Item: **RESOLUTION 2024-31 – CONSIDERATION AND APPROVAL OF CONTRACT AMENDMENT NUMBER 11 WITH HDR ENGINEERING, INC. TO INCREASE THE MAXIMUM PAYABLE AMOUNT FOR SUPPLEMENTAL NUMBER 3 TO WORK AUTHORIZATION NUMBER 8.**

2. Nature of Request: (Brief Overview) Attachments: X Yes No

Consideration and Approval of CA No. 11 for SA No.3 WA 8 to the PSA with HDR Engineering, Inc. to provide Construction Inspection Services for the 365 Tollway Project.

3. Policy Implication: Board Policy, Local Government Code, Texas Government Code, Texas Transportation Code, TxDOT Policy

4. Budgeted: X Yes No N/A

5. Staff Recommendation: **Motion to Approve Resolution 2024-31 – Consideration and Approval Contract Amendment Number 11 with HDR Engineering Inc. to increawe the maximum payable amount for Supplemental Number 3 to Work Authorization number 8, as presented.**

6. Program Manager’s Recommendation: Approved Disapproved X None

7. Planning Committee’s Recommendation: Approved Disapproved X None

8. Board Attorney’s Recommendation: Approved Disapproved X None

9. Chief Auditor’s Recommendation: Approved Disapproved X None

10. Chief Financial Officer’s Recommendation: Approved Disapproved X None

11. Chief Development Engineer’s Recommendation: Approved Disapproved X None

12. Chief Construction Engineer’s Recommendation: X Approved Disapproved None

13. Executive Director’s Recommendation: X Approved Disapproved None



- CMT Services
- Environmental
- Engineering **HDR Engineering, Inc.**
- Geo-Technical
- Surveying

CONTRACT AMENDMENT SUMMARY

RESOLUTION 2022-31

Original Contract Amount **\$ 488,658**

Amendment # 11

Amount **\$ 1,009,480.30**

Approved Amendments

Resolution No.	Description	Amount
2019-01	PSA to provide General Consultant Services	\$ 488,657.91
2020-37	Contract Amendment 2 Due SA1WA 2 & WA 3	\$ 331,714.69
2021-22	Contract Amendment 2 for WA 4	\$ 197,746.02
2021-52	Contract Amendment 3 for WA 5 & WA 6	\$ 389,468.97
2022-12	Contract Amendment 4 for WA 7	\$ 119,970.68
	Subtotal from Cont. Page	\$ 3,963,771.09
	Contract Amount	\$ 5,491,329.36
Proposed Amendment		
2024-31	Contract Amendment 11 for SA3 to WA8	\$ 1,009,480.30

Goals & Options:

Consideration and Approval of Contract Amendment Number 11 to the Professional Service Agreement with HDR Engineering to increase the maximum amount payable for Supplemental Number 3 to Work Authorization No. 8

Staff is recommending approval of this request in the amount of \$ 1,009,480.30 for a Revised Maximum Payable Amount of \$ 6,500,809.66

P. Rodriguez, ED
Requested by:

Approved Amendments Cont...**Resolution No.**

2024-31

Resolution No.	Description	Amount
2022-23	Contract Amendment 5 for WA8	\$ 1,244,594.55
2022-53	CA 6 for SA2 for WA3 & SA1 for WA4	\$ 174,053.41
2023-08	CA 7 - revised rates for GEC & PM for 365 Toll	\$ 0.00
2023-17	Contact Amendment 8 for SWA3 for WA3	\$ 289,198.08
2023-29	Contract Amendment 9 for SA1 to WA8 & WA9	\$ 1,654,929.39
2023-45	Contract Amendment 10 for SA2 to WA8	\$ 600,995.66

Subtotal \$ 3,963,771.09

HIDALGO COUNTY REGIONAL MOBILITY AUTHORITY

BOARD RESOLUTION No. 2024-31

RESOLUTION 2024-31 – CONSIDERATION AND APPROVAL OF CONTRACT AMENDMENT NUMBER 11 TO THE PROFESSIONAL SERVICE AGREEMENT WITH HDR ENGINEERING TO INCREASE THE MAXIMUM PAYABLE AMOUNT FOR SUPPLEMENTAL NUMBER 3 TO WORK AUTHORIZATION NUMBER 8

THIS RESOLUTION is adopted this 25th day of June 2024, by the Board of Directors of the Hidalgo County Regional Mobility Authority at a regular meeting.

WHEREAS, the Hidalgo County Regional Mobility Authority (the “Authority”), acting through its Board of Directors (the “Board”), is a regional mobility authority created pursuant to Chapter 370, Texas Transportation Code, as amended (the “Act”);

WHEREAS, the Authority is authorized by the Act to address mobility issues in and around Hidalgo County;

WHEREAS, on February 22, 2012 the Authority approved Resolution 2012-04, which created the Technical Committee, comprised of senior level engineers and professional from various communities and agencies in the jurisdiction of the Authority, to serve to advise the Board on procurement and consultant work products; and

WHEREAS, Resolution 2012-04 also authorized the Executive Committee to determine the size, structure and scope of the Technical Committee, identify candidates and issue requests for participation; and

WHEREAS, February 27, 2018, the Authority approved Resolution 2018-07 which for the procurement of Professional Engineering Services for a General Engineering Consultant for the Hidalgo County Loop System including, but not limited to Advance Project Development and Construction Management Support; and

WHEREAS, the Technical Committee has rated and ranked the Statements of Qualifications for the General Engineering Consultant Services and recommends interviews be dispensed with and that staff be authorized to negotiate with HDR Engineering, Inc.;

WHEREAS, on February 26, 2019 the Authority approved Resolution 2019-01 Approval of a Professional Service Agreement with HDR Engineering, Inc. to provide General Consultant Services for the Hidalgo County Loop System of the Hidalgo County Regional Mobility Authority in the amount of \$488,657.91; and

WHEREAS, on March 5, 2019 the Authority approved approve Resolution 2019-02 Approval of a Work Authorization 1 to the Professional Service Agreement with HDR

Engineering, Inc. Project Management for the 365 Tollway Project in the amount of \$171,350.84; however, no notice to proceed was issued; and

WHEREAS, on November 17, 2020 in order to reflect a change in the planned series of tasks relating to a changed project letting schedule, the Board found it to be in the best interest of the Authority to approve Resolution 2020-32 Approval of Amended and Restated Work Authorization 1 to the Professional Service Agreement with HDR Engineering, Inc. for General Engineering Consulting Services for the 365 Tollway Program Management Support in the amount of \$301,579.58; and

WHEREAS, on November 17, 2020 the Authority approved Resolution 2020-33 Approval of a Work Authorization 2 to the Professional Service Agreement with HDR Engineering, Inc. for General Engineering Consultant Services for the 365 Tollway Roadway Construction Contract Letting Support in the amount of \$125,723.03; and

WHEREAS, on December 15, 2020 the Authority approved Resolution 2020-35 Approval of Supplemental Agreement 1 to Work Authorization 2 to the Professional Service Agreement with HDR Engineering, Inc. for General Engineering Consultant Services for the 365 Tollway Roadway Construction Contract Letting Support in the amount of \$93,284.63; and

WHEREAS, on December 15, 2020 the Authority approved Resolution 2020-36 Approval of a Work Authorization 3 to the Professional Service Agreement with HDR Engineering, Inc. for General Engineering Consultant Services for the 365 Tollway Integration Contract Letting Support in the amount of \$299,785.36; and

WHEREAS, on December 15, 2020 the Authority approved Resolution 2020-37 Approval of Contract Amendment 1 to the Professional Service Agreement with HDR to increase the maximum payable amount from \$488,657.91 to \$820,372.60 for a total increase of \$331,714.69 due to additional scope and effort outlined in Supplemental Agreement 1 to Work Authorization No. 2 and Work Authorization No. 3; and

WHEREAS, on June 22, 2021 the Authority approved Resolution 2021-21 Approval of a Work Authorization 4 to the Professional Service Agreement with HDR Engineering, Inc. for IBTC final schematic Support for the Environmental Clearance in the amount of \$197,746.02; and

WHEREAS, on June 22, 2021 the Authority approved Resolution 2021-22 Approval of Contract Amendment 2 to the Professional Service Agreement with HDR to increase the maximum payable amount from \$820,372.60 to \$1,018,118.62 for a total increase of \$197,746.02 for Work Authorization No. 4; and

WHEREAS, on December 20, 2021 the Authority approved Resolution 2021-51 Approval of a Work Authorization 5 to the Professional Service Agreement with HDR Engineering, Inc. for engineering support for the design and construction of the 365 Tollway Wetland Mitigation site in the amount of \$310,039.40; and

WHEREAS, on December 20, 2021 the Authority approved Resolution 2021-74 Consideration and Approval of Work Authorization 6 with HDR Engineering, Inc. for engineering support for review of the 365 Tollway Value Engineering Change Proposals in the amount of \$79,429.57; and

WHEREAS, on December 20, 2021 the Authority approved Resolution 2021-52 Approval of Contract Amendment 3 to the Professional Service Agreement with HDR to increase the maximum payable amount from \$1,018,118.62 to \$1,407,587.59 for a total increase of \$389,468.97 for Work Authorization No. 5 & Work Authorization No. 6; and

WHEREAS, on January 25, 2022 the Authority approved Resolution 2022-02 Consideration and Approval of Work Authorization 1 Supplemental 1 to the Professional Service Agreement with HDR Engineering, Inc. for a no-cost time extension for general engineering consulting services to the Hidalgo County Regional Mobility Authority; and

WHEREAS, on January 25, 2022 the Authority approved Resolution 2022-03 Consideration and Approval of Work Authorization 2 Supplemental 2 to the Professional Service Agreement with HDR Engineering, Inc. for a no-cost time extension for general engineering consulting services to the Hidalgo County Regional Mobility Authority; and

WHEREAS, on January 25, 2022 the authority approved Resolution 2022-04 Consideration and Approval of Work Authorization 3 Supplemental 1 to the Professional Service Agreement with HDR Engineering, Inc. for a no-cost time extension for general engineering consulting services to the Hidalgo County Regional Mobility Authority; and

WHEREAS, on February 22, 2022 the Authority approved Resolution 2022-11 - Consideration and Approval of Work Authorization 7 with HDR Engineering, Inc. for engineering services for the review for the updated design initiated under the 365 Tollway Value Engineering Change Proposal process in the amount of \$119,970.68; and

WHEREAS, on March 22, 2022 the Authority approved Resolution 2022-22 – Consideration and Approval of Work Authorization Number 8 with HDR Engineering, Inc. for general engineering services for construction management of the 365 Tollway in the amount of \$1,244,594.55; and

WHEREAS, on April 26, 2022 the Authority through Resolution 2022-32 approved Work Authorization 2 Supplemental 3 to the Professional Services Agreement with HDR Engineering, Inc. for a no-cost time extension for general engineering consulting services to the Hidalgo County Regional Mobility Authority through July 31, 2022; and

WHEREAS, on August 23, 2022 the Authority approved Resolution 2022-53 approval of contract amendment 6 to the professional service agreement with HDR Engineering to increase the maximum payable amount for supplemental number 2 to work authorization number 3 to \$88,206.93 and supplemental number 1 to work authorization number 4 to \$85,846.48 with HDR Engineering, Inc.; and

WHEREAS, on February 28, 2023 the Authority approved Resolution 2023-08 approving Contract Amendment Number 7 to the Professional Service Agreement with HDR Engineering for revised hourly rates for General Engineering Consultant and Program Manager Services for the 365 Tollway and IBTC Projects hereto attached as Exhibit A.; and

WHEREAS, on March 14, 2023 the Authority approved Resolution 2023-13 approving of Supplemental Number 3 to Work Authorization Number 3 to the Professional Service Agreement with HDR Engineering in the amount of \$289,198.08 to provide Toll System Integrator procurement support and an update of the Maintenance & Operation Financial Model for the 365 Tollway Project; and

WHEREAS, on June 27, 2023 the Authority approved Resolution 2023-27 approving of Work Authorization Number 9 to the Professional Service Agreement with HDR Engineering in the amount of 1,427,870.83 for the next phase of TSI coordination and implementation for the 365 Tollway; and

WHEREAS, the Authority finds it necessary to approve Resolution 2023-35 approving of Work Authorization Number 3 Supplemental Number 4 to the Professional Service Agreement with HDR Engineering for a no-cost time extension for General Engineering Consulting Services to the Hidalgo County Regional Mobility Authority.

WHEREAS, on October 24, 2023, the Authority approved Resolution 2023-44 approving of Work Authorization Number 8 Supplemental Number 2 to the Professional Service Agreement with HDR Engineering general engineering services for construction management of the 365 Tollway in the amount of \$600,995.66; and

WHEREAS, on October 24, 2023, the Authority approved Resolution 2023-45 approving of Contract Amendment 10 to the Professional Service Agreement with HDR Engineering to increase the maximum payable amount from \$4,890,333.70 to \$5,491,329.36 for a total of \$600,995.66 for Work Authorization Number 8 Supplemental Number 2; and

WHEREAS, on December 12, 2023 the Authority approved Resolution 2023-53 approving of Work Authorization Number 5 Supplemental Number 2 to the Professional Service Agreement with HDR Engineering for a no-cost time extension for engineering support for the design and construction of the 365 Tollway Wetland Mitigation; and

WHEREAS, the Authority finds it necessary to approve Resolution 2024-31 approving of Contract Amendment 11 to the Professional Service Agreement with HDR Engineering to increase the maximum payable amount from \$5,491,329.36 to \$6,500,809.66 for a total increase of \$1,009,480.30 for Work Authorization number 8 Supplemental Number 3.

NOW THEREFORE, BE IT RESOLVED, BY THE BOARD OF DIRECTORS OF THE HIDALGO COUNTY REGIONAL MOBILITY AUTHORITY THAT:

- Section 1. The recital clauses are incorporated in the text of this Resolution as if fully restated.
- Section 2. The Board hereby approves of Contract Amendment Number 11 to the Professional Service Agreement with HDR Engineering for general engineering services, hereto attached as Exhibit A.
- Section 3. The Board authorizes the Executive Director to execute Contract Amendment Number 11 to the Professional Services Agreement with HDR.

PASSED AND APPROVED AS TO BE EFFECTIVE IMMEDIATELY BY THE BOARD OF DIRECTORS OF THE HIDALGO COUNTY REGIONAL MOBILITY AUTHORITY AT A REGULAR MEETING, duly posted and noticed, on the 25th day of June 2024, at which meeting a quorum was present.

S. David Deanda, Jr., Chairman

Juan Carlos Del Ángel, Secretary/Treasurer

**CONTRACT AMENDMENT NUMBER 11
TO PROFESSIONAL SERVICES AGREEMENT
FOR GENERAL ENGINEERING CONSULTING SERVICES**

THIS CONTRACT AMENDMENT NUMBER 11 TO MAIN CONTRACT is made pursuant to the terms and conditions of “Article V of that certain Professional Services Agreement for General Engineering Consulting Services” hereinafter identified as the “Agreement,” entered into by and between the Hidalgo County Regional Mobility Authority (Authority), and HDR Engineering. (the GEC).

Article II Agreement Period

This revised Agreement becomes effective when fully executed by all parties hereto and it shall terminate at the close of business January 31, 2026.

Article III Compensation

Article III Compensation shall be amended to increase the amount payable under this contract from \$5,491,329.36 to \$6,500,809.66 for a total increase of \$1,009,480.30 due to additional scope and effort outlined in Supplemental Agreement 3 to Work Authorization Number 8.

This Contract Amendment Number 11 to the Professional Services Agreement shall become effective on the date of final execution of the parties hereto. All other terms and conditions of the Agreement not hereby amended are to remain in full force and effect.

IN WITNESS WHEREOF, this Contract Amendment is executed in duplicate counterparts and hereby accepted and acknowledged below.

THE GEC

THE AUTHORITY

(Signature)
David C. Weston

(Signature)
Pilar Rodriguez, P.E.

Vice President
(Title)

Executive Director
(Title)

(Date)

(Date)

THIS ITEM WILL BE
SENT UNDER
SEPERATE COVER

Item 3E

HIDALGO COUNTY REGIONAL MOBILITY AUTHORITY

AGENDA RECOMMENDATION FORM

BOARD OF DIRECTORS	<u> X </u>	AGENDA ITEM	<u> 3E </u>
PLANNING COMMITTEE	<u> </u>	DATE SUBMITTED	<u> 06/20/24 </u>
FINANCE COMMITTEE	<u> </u>	MEETING DATE	<u> 06/25/24 </u>
TECHNICAL COMMITTEE	<u> </u>		

1. Agenda Item: **RESOLUTION 2024-32 – CONSIDERATION AND APPROVAL TO PROCEED WITH AWARD OF CONTRACT TO MITRES SERVICES LLC WAIVING TXDOT PRECERTIFICATION REQUIREMENTS FOR PREQUALIFIED BIDDER**

2. Nature of Request: (Brief Overview) Attachments: Yes No

Consideration and approval of Award of Contract to MitRes Services, LLC. for the Granjeno Wetland Mitigation Project

3. Policy Implication: Board Policy, Local Government Code, Texas Government Code, Texas Transportation Code, TxDOT Policy

4. Budgeted: Yes No N/A

5. Staff Recommendation: **Motion to approve Resolution 2024-32 – Consideration and Approval to proceed with award of contract to MitRes Services LLC waiving TxDOT precertification requirements for prequalified bidder.**

6. Program Manager’s Recommendation: Approved Disapproved None

7. Planning Committee’s Recommendation: Approved Disapproved None

8. Board Attorney’s Recommendation: Approved Disapproved None

9. Chief Auditor’s Recommendation: Approved Disapproved None

10. Chief Financial Officer’s Recommendation: Approved Disapproved None

11. Chief Development Engineer’s Recommendation: Approved Disapproved None

12. Chief Construction Engineer’s Recommendation: Approved Disapproved None

13. Executive Director’s Recommendation: Approved Disapproved None



HCRMA
HIDALGO COUNTY REGIONAL MOBILITY AUTHORITY

Memorandum

To: Pilar Rodriguez, PE, Executive Director

From: Ramon Navarro IV, PE, Chief Construction Engineer

Date: April 18, 2024

Re: Resolution 2024-32 Consideration and Approval to proceed with award of contract to MitRes Services LLC waiving TxDOT precertification requirements for prequalified bidder

Background

The Granjeño Wetland Mitigation Project consists of the restoration of 23.88 acres of land planned specifically for wetland restoration of 80.2 acres of HCRMA property dedicate to wetlands to compensate environmental justice for impacts resulting from the 365 Toll project. The remaining acres of restored wetland area at the mitigation site will be held in reserve for application toward future projects within the watershed. The project consists of grading and compaction of approximately 19 Acres to establish a wetland which includes placement of a clay liner and plant root zone soil strata. It also includes berm grading and compaction of approximately 6 Acres of upland area. Construction of an access driveway and road including maintenance and brush clearing/tree trimming, of a groundwater well with controls and approximately 3,000 linear feet of PVC pipe distribution, and a security fence for the groundwater well and associated equipment.

History

December 6, 2023, a Bid Opening for subject project took place. We received two electronic bids via CivCast; however, due to plan errors all bids were rejected. Design was amended and letting process was re-initiated. The Engineer's O p i n i o n o f P r o b a b l e C o n s t r u c t i o n C o s t for the project was \$2,630,000.

March 13, 2024, a Bid Opening for Project BID#2024-004, the Granjeño Wetland Mitigation Site (Granjeño) Project took place. HCRMA received one electronic bids via CivCast. The lone bidder was MitRes at \$5,850,993.87. On March 26, 2024, the Board approved award of contract contingent to TxDOT / FHWA concurrence.

May 29, 2024, TxDOT recognized that the subject project is fully funded by bond proceeds issued by HCRMA; no state of federal dollars are being used for this construction. Therefore, TxDOT is not required to provide concurrence for the award of this procurement.

Recommendation

Based on review by Legal, HDR [GEC], and HCRMA staff it is recommended to award the construction and immediately issue Notice to Proceed to the lowest, responsive and responsible bidder MitRes Services, LLC. for construction of the Project in the amount of \$5,850,993.87 to be completed in 180 days.

HIDALGO COUNTY REGIONAL MOBILITY AUTHORITY BOARD RESOLUTION
2024- 08

CONSIDERATION AND APPROVAL OF AWARD OF CONTRACT TO MITRES SERVICES, LLC, FOR THE GRANJENO WETLAND MITIGATION SITE PROJECT

THIS RESOLUTION is adopted this 23rd day of January, 2024 by the Board of Directors of the Hidalgo County Regional Mobility Authority.

WHEREAS, the Hidalgo County Regional Mobility Authority (the "Authority"), acting through its Board of Directors (the "Board"), is a regional mobility authority created pursuant to Chapter 370, Texas Transportation Code, as amended (the "Act");

WHEREAS, the Authority is authorized by the Act to address mobility issues in and around Hidalgo County, including the development of the 365 Toll project (the "Project");

WHEREAS, the Project was environmentally cleared in 2015;

WHEREAS, the U.S. Army Corps of Engineers issued Individual Permit No. SWG-2013-00175 (the "Permit") for the Project;

WHEREAS, the Permit requires the Authority to conduct a compensatory wetland mitigation (the "Mitigation Plan");

WHEREAS, the Permit additionally requires that the area on which the Mitigation Plan is to be conducted be covered by a conservation easement held by an approved wildlife conservation organization in perpetuity, which easement is to be recorded in the real property records of Hidalgo County, Texas (the "Conservation Easement");

WHEREAS, the Valley Land Fund Inc., a Texas non-profit corporation, is a wildlife conservation organization established to preserve, enhance, and expand the native wildlife habitat of the Rio Grande Valley;

WHEREAS, the governing body of the Valley Land Fund Inc. has or will approve its acceptance of the Conservation Easement; and

WHEREAS, the Board now finds it to be in the best interest of the Authority to provide the open space and environmental values described in the Conservation Easement;

WHEREAS, on August 24, 2021 the Board authorized Executive Director, to accept and execute the Conservation Easement, as approved by the Valley Land Fund Inc. in final form and have the same recorded in the real property records of Hidalgo County, Texas

WHEREAS the Authority publicly advertised and conducted a mandatory attendance, Pre-bid Meeting on Tuesday, November 21, 2023; 2:00 P.M. C.S.T., at the Hidalgo County Regional Mobility Authority Offices; the HCRMA entertained Questions / RFI's via the project's CivCAST listing, and provided timely answers up and till 3:00 P.M. C.S.T. on Wednesday, November 29, 2023

WHEREAS, at 2:45PM on December 6, 2023 the Authority received two (2) formal sealed, electronic bids for the Project; and at 3:05 p.m., the Authority opened and read into the record two (2) formal sealed, electronic bids for the Project from: (i) JMJ Constructors, (ii) and MitRes Services, LLC. in amounts ranging from \$3,229,980.00 to \$5,117,103.16 for construction of the Project; and

WHEREAS, due to discovered plan error, and in the best interest of the Authority; HCRMA Staff and GEC (HDR) on January 29, 2024 rejected all bids;

WHEREAS, the Authority publicly re-advertised and conducted a mandatory attendance, Pre-bid Meeting on Tuesday, February 20, 2024; 2:00 P.M. C.S.T., at the Hidalgo County Regional Mobility Authority Offices, and via TEAMS [Meeting ID: 256 105 661 046] ; the HCRMA entertained Questions / RFI's via the project's CivCAST listing, and provided timely answers up and till 3:00 P.M. C.S.T. on Friday, March 8, 2024;

WHEREAS, at 1:39PM on March 13, 2024 the Authority received one (1) formal sealed, electronic bids for the Project; and at 3:05 p.m., the Authority opened and read into the record one (1) formal sealed, electronic bids for the Project from: (i) MitRes Services, LLC.;

WHEREAS, on March 26, 2024, the Authority opened and read into the record one (1) formal sealed, electronic bids for the Project from: (i) MitRes Services, LLC. in amount of \$5, 850,993.87 for construction of the Project; and

WHEREAS, pursuant to the Act; HCRMA Staff and GEC (HDR) reviewed proposals; and the the Board approved award of contract to MitRes Services, LLC. contingent to partnering agency's concurrence in the amount of \$5,850,993.87 for construction of the Project;

WHEREAS, on May 29, 2024, TxDOT recognized that the subject project is fully funded by bond proceeds issued by HCRMA; no state or federal dollars are being used for this construction. Therefore, TxDOT is not required to provide concurrence to HCRMA for the award of this procurement; and,

THEREFORE, pursuant to the Act the Board finds that awarding the construction contract to MitRes Services, LLC. in the amount of \$5,850,993.87 for construction of the Project is in the best interest of the Authority;

NOW THEREFORE, BE IT RESOLVED, BY THE BOARD OF DIRECTORS OF THE HIDALGO COUNTY REGIONAL MOBILITY AUTHORITY THAT:

Section 1. The recital clauses are incorporated in the text of this Resolution as if fully restated.

Section 2. The Board hereby awards the Granjeno Wetland Mitigation Project to MitRes Services, LLC. and approves the Contract attached hereto as Exhibit A.

Section 3. The Board authorizes the Executive Director to execute the Contract.

PASSED AND APPROVED AS TO BE EFFECTIVE IMMEDIATELY BY THE BOARD OF DIRECTORS OF THE HIDALGO COUNTY REGIONAL MOBILITY AUTHORITY AT A REGULAR MEETING on the 25th day of June, 2024, at which meeting a quorum was present.

S. David Deanda, Jr., Chairman

Ezequiel Reyna, Jr., Secretary/Treasurer

Memo

Date: Tuesday, May 07, 2024

Project: Granjeno Wetland Mitigation Site

To: Norma Garza, PE

From: Pilar Rodriguez, Ramon Navarro, Sam Saldivar

Subject: Recommendation of the Low Bid for Granjeno Wetland Mitigation Site

On Wednesday, March 13, 2024, the HCRMA opened Bid No. 2024-004 for the Granjeno Wetland Mitigation Site (Project). The project was advertised on The Monitor and the HCRMA website starting on Saturday, February 17, 2024 and repeated on February 21st, 24th, and 28th as shown in Attachment A. A mandatory pre-bid meeting was held at the HCRMA office at 203 W. Newcombe Ave, Pharr TX 78577 and hosted virtually via Microsoft Teams.

Bidders were directed from the HCRMA website to CivCast (URL: [CIVCAST | Advertise, Manage, and Receive Construction Bids and RFQs \(civcastusa.com\)](https://www.civcastusa.com)) where electronic distribution of bid documents (plans, bidding documents including bid form, addendum #1) and other data (USACE permits, Geotechnical Report, Pre-bid Agenda/Attendees) was available to plan holders. The HCRMA received three (3) questions which were answered and handled through the CivCast online format. Questions are included as Attachment C.

Bids were opened and read aloud on Wednesday, March 13, 2024 at the HCRMA office at 203 W. Newcombe Ave, Pharr TX 78577. Attachment B shows the pre-bid agenda and bid opening attendees who joined in-person or online (virtual Microsoft Teams), respectively. There was one (1) bidder who submitted, MitRes Services, LLC. The HCRMA has determined MitRes Services to be responsive and qualified to perform the work as per the bidding requirements. They have submitted all the required bidding documents (Attachment E), and their bid did not appear to be unbalanced. It was difficult to find comparable pricing for this project's site development work since it is unique and non-linear. It was expected that the Bidder's unit costs would be higher and lower depending on the bid item. The bid analysis is included as Attachment D.

In summary, the HCRMA recommends awarding this contract to MitRes Services, LLC as they are the responsive qualified low bidder. This memo serves as the next step whereas the HCRMA is requesting TxDOT concurrence prior to execution of an Agreement between the HCRMA and MitRes Services, LLC.

From: [Norma Garza](#)
To: [Saldivar Jr., Samuel](#); [Ramon Navarro, IV, PE, CFM](#)
Cc: [Pilar Rodriguez, PE](#); [Pena, Sierra](#); [Daniel Garcia](#); [John Jameson](#)
Subject: RE: HCRMA Granjeno Wetland Mitigation Site: Award Recommendation
Date: Wednesday, May 29, 2024 10:22:38 AM
Attachments: [2024-05-07 Granjeno Award Recommendation.pdf](#)
[FHWA Bid Analysis and Unbalanced Bids.pdf](#)

Good morning, Sam & Ramon.

We have conducted our review of the submitted documents pertaining to the Granjeno Wetland Mitigation Site. As per the email submitted by Mr. Pilar Rodriguez clarifying that the Site work construction would be paid by bond proceeds issued by HCRMA; no state or federal dollars are being used for this construction. Therefore, TxDOT is not required to provide concurrence to HCRMA for the award of this procurement.

However, in our review we noted some issues/concerns that should be reviewed by your legal/procurement team before taking further action.

We noted the following issues:

- **Requirement for the responsive and responsible bidder to be currently prequalified with TxDOT-** MitRes is not prequalified with TxDOT, therefore, they are not a responsive bidder
- **Requires 6% DBE goal-** if no federal funds are being used, then DBE goal does not apply. However, if it is a requirement of this procurement is the proposed bidder meeting this requirement?
- **Based on the bid and bid analysis provided, it appears that the bid is mathematically unbalanced, front loaded, and includes token bid prices.** Further evaluation and consideration by the HCRMA should be performed.

Please see the attached documents for more details.

If you have any further questions, feel free to contact me.

Regards,
Norma

Norma Y. Garza, P.E.

Director of Transportation Planning & Development

District RMA Liaison

TxDOT- Pharr District

Email: norma.garza@txdot.gov

Phone: (956) 702-6180 Office

(956) 638-3518 Mobile

From: Saldivar Jr., Samuel <Samuel.Saldivar@hdrinc.com>

Sent: Tuesday, May 7, 2024 9:56 AM

To: Norma Garza <Norma.Garza@txdot.gov>

Cc: Pilar Rodriguez (prodriguez@hcrma.net) <prodriguez@hcrma.net>; Ramon Navarro, IV, PE, CFM <ramon.navarro@hcrma.net>; Pena, Sierra <Sierra.Pena@hdrinc.com>

Subject: HCRMA Granjeno Wetland Mitigation Site: Award Recommendation

This email originated from outside of the organization. Do not click links or open attachments unless you recognize the sender and know the content is safe.

Hello Ms. Garza.

Please find attached the HCRMA's formal request for TxDOT concurrence of awarding the Granjeno Wetland Mitigation Site project to MitRes Services, LLC.

We appreciate your time.

Thank you,

Samuel Saldivar, Jr., PE
Civil Program Leader, Associate

HDR
555 N. Carancahua, Suite 1600
Corpus Christi, TX 78401-0849
D 361.696.3325 **M** 361.793.5735
samuel.saldivar@hdrinc.com

hdrinc.com/follow-us





Memo

Date: Tuesday, June 11, 2024

Project: Granjeno Wetland Mitigation Site Project

To: Norma Garza, PE

CC: Pilar Rodriguez, Ramon Navarro, Dan Paredes, Blakely Fernandez

From: Samuel Saldivar

Subject: Recommendation to Continue Award of Construction Contract

The HCRMA, legal counsel, and HDR are in receipt TxDOT's response to the recommendation to award the Granjeno Wetland Mitigation Site project (Bid No. 2024-004) to MiteRes Services, LLC. This memo provides a response to the following comments/questions.

- Is MitRes Services, LLC a TxDOT prequalified bidder?
 - Response: The HCRMA and HDR stipulated in the bidding documents that TxDOT precertification was required. While this was preferred, there was concern that there were no TxDOT prequalified bidders with the experience or interest to deliver they type of site work. During the first bidding of this project, Bid No. 2023-001, only two bidders engaged the HCRMA with questions and bids. Neither were TxDOT prequalified, but they displayed examples of the work experience needed to the deliver this project. A bidder question was received asking about the TxDOT prequalification requirement. I recommended to the HCRMA that the requirement be waived to move forward with bidding and construction. To avoid losing additional time to construct this project, I recommended the same waiver be accommodated with the Re-Bid (Bid No. 2024-001) to avoid a no-bids-received scenario to the bidding advertisement. It is imperative that the Contractor has a strong experience with civil site environmental mitigation, and TxDOT prequalification is a bid formality that does not help in that regard.
- Bid appears to be mathematically unbalanced.
 - Response: Remote site work with a scope of work that focuses on soil management, planting, and groundwater well installation is an uncommon project type. The bid items which represent 14% or more of the total bid price which exceeded the Engineer's Unti Price indicate where the Contractor has assigned the most effort and risk. It is reasonable to see higher prices for these items.



I recommend the HCRMA move forward with awarding the contract to MitRes Services, LLC for the following reasons:

- MitRes Services, LLC has well over 10 years of experience with environmental restoration projects. They have delivered large-scale infrastructure projects, including restoration of 359,000 linear feet of streams and over 1,500 acres of wetlands.
- HCRMA and HDR have bid this project twice. We will lose time if we have to bid this project a third time. We are nearing the end of the procurement window to secure the plant species type required for the project. If the project is rebid, the third bidding will need to be delayed until the first quarter of 2025.
- Delaying the project another year will subject the project to increased cost due to yearly and market drive cost increases. The project has already seen at least a 38% increase since preparing for bid advertisement.
- The project is not utilizing state or federal funds. The funding of this project is through local revenue; therefore, it is a non-participating project.

Samuel Saldivar, Jr., PE

**ATTACH CONTRACT
&
ATTACH PLANS**

Advertisement and Invitation to Bidders
Request for sealed bids for
Hidalgo County Regional Mobility Authority BID #2024-004
for the
Granjeno Wetland Mitigation Site Project
CONTRACT NO. 07-E36-19-04

Bid opening date and time: **Wednesday, March 13, 2024, Until 3:00 P.M. C.S.T.**

Pre-Bid Meeting: Tuesday, February 20, 2024, 2 P.M. C.S.T. (MANDATORY)
In-person or Virtual Attendance Option

Local Government Sponsor: Hidalgo County Regional Mobility Authority (HCRMA)
Pilar Rodriguez, PE, Executive Director
203 W. Newcombe Ave, Pharr, Texas 78577
Telephone / Fax: (956) 402-4762 / (956) 475-3451

Bid Documents for Construction of the Granjeno Mitigation Site (Granjeno) may be obtained from the HCRMA website at no expense via a CivCAST project listing that will be published to <http://www.hcrma.net/bids.html>. The Granjeno project is for the restoration of 23.88 acres of land, including approximately 17 acres planned specifically for wetland restoration. HCRMA will dedicate 12 of the 17 acres to compensate for impacts resulting from the 365 Toll project (also referred to as the SH 365 roadway project in the mitigation plan). The remaining 5 acres of restored wetland area at the mitigation site will be held in reserve for application toward future projects within the watershed. The project consists of grading and compaction of approximately 19 Acres to establish a wetland which includes placement of a clay liner and plant root zone soil strata. It also includes berm grading and compaction of approximately 6 Acres of upland area. Construction of an access driveway and road including maintenance and brush clearing/tree trimming, of a groundwater well with controls and approximately 3,000 linear feet of pvc pipe distribution, and a security fence for the groundwater well and associated equipment. .

Electronic bids via CivCast will be received by the HCRMA, **until 3:00 P.M. C.S.T., Wednesday, March 13, 2024**. Bids will be opened and read aloud at the HCRMA Offices at 203 W. Newcombe Ave, Pharr, Texas 78577 at 3:05 P.M. C.S.T. on deadline due date. Bids received after the previous mentioned date and time will not be considered and will be rejected. The HCRMA reserves the right to accept or reject all or any part of any bid; hold all bids for 120 days from due date of receipt without actions, waive minor technicalities, require statements or evidence of bidder's qualifications, including financial statements, and **award the lowest responsive and responsible bidder. Acceptance will be based on low bid of a responsive and responsible contractor that is currently prequalified to do construction work with TxDOT. Award of bid shall be subject to a final contract award by the HCRMA Board of Directors.**

A Pre-bid Meeting will be held for this project on Tuesday, February 20, 2024 at 2:00 P.M. C.S.T., at the HCRMA Offices at 203 W. Newcombe Ave, Pharr, Texas 78577. The Pre-bid Meeting is **MANDATORY** and prospective bidders must attend (in-person or virtually) to have their proposal opened. HCRMA Staff and General Engineering Consultant will review plans, specifications, details, materials and requirements of the work, and therefore Sub-contractors and materials suppliers who expect to be associated with the project are invited to attend.

Any Contractor intending to bid on this project must be prequalified by Texas Department of Transportation (TxDOT) and able to conduct work within State Right-of-Way. Bid security in the amount of five (5%) percent of the total bid submitted must accompany each proposal in accordance with the Invitation to Bid. Performance and payment bonds for one hundred (100%) percent of the contract value will be required upon issuance of the contract. In accordance with 49 CFR Part 26 and based on the project's Federal funding, type of work, location, overall and item cost estimate values, subcontracting opportunities, certified DBE firms in vicinity of the project location, and size of the project TxDOT's Office of Civil Rights assigns a race-conscious DBE goal of six (6.0%) percent for this project proposal.

The HCRMA will only entertain Questions / RFI's via the project's CivCAST listing, and the HCRMA will provide timely answers (and potentially issue addenda, as needed). Questions / RFI's will not be answered by phone or any other means other than CivCAST. All inquiries shall be submitted by 3:00 P.M. C.S.T. on Friday, March 8, 2024. Inquiries beyond this date will not be responded, and Addenda will be available wherever Bid Documents are made available.

The Hidalgo County Regional Mobility Authority, in accordance with the provisions of Title VI of the Civil Rights Act of 1964, (78 Stat. 252, 42 U.S.C 2000d to 2000d-4) and the Regulations, hereby notifies all bidders that it will affirmatively ensure that for any contract entered into pursuant to this advertisement, disadvantaged business enterprises will be afforded full and fair opportunity to submit bids in response to this invitation and will not be discriminated against on the grounds of race, color, or national origin in consideration for an award.

TO BE PUBLISHED IN THE MONITOR ON SATURDAY 02/17/2024, WEDNESDAY 02/21/2024, SATURDAY 02/24/2024, AND WEDNESDAY 02/28/2024.

Agenda

Project:	HCRMA Granjeno Wetland Mitigation Project	
Subject:	Pre-Bid Meeting (Bid No. 2024-004) (2:11pm)	
Date:	Tuesday, February 20, 2024	
Location:	203 W Newcombe Ave, Pharr TX 78577	
Attendees:	Bradley C Tilbury (Mitres)	Brad McKelvey (Engineering Resources)
	Samuel Saldivar (HDR)	Colin Cox (Mitres)
	Eric Slusser (Mitres)	Daniel Kampfer
	Device Board (HCRMA)	Joe Olivares (GO Underground)
	Royce Williams (Tritan ENV Solutions)	JMJ Constructors
	Zach Rosen (RES)	Ramon Navarro (HCRMA)

- Introductions (HCRMA and HDR)
- Project Description
 - Granjeno Wetland Mitigation Site Project
- Project Location
 - Site Visit (highly recommended), Article 5 of ITB
 - Bidders who have a documented project site visit as part of Bid No. 2023-001 are not required to revisit the site as part of Bid No. 2024-004.
- Project Items to Note
 - Bid Form (attach to agreement)
 - Wetland Area
 - Groundwater Well Pump
 - Plant species availability – Diligently follow the planting specification for acceptable plant species types, and be proactive to procure the volume of plants required for the project.
- Construction Schedule
 - 180 days from NTP, Calendar Days
- Q&A
 - Questions asked during the pre-bid meeting will be posted to Civcast.

Agenda

Project:	HCRMA – Granjeno Wetland Mitigation Site	
Subject:	Bid Opening	
Date:	Wednesday, March 13, 2024	
Location:	203 W. Newcombe Ave, Pharr, TX 78577 & Online (Virtual Teams)	
Attendees:	Ramon Navarro	Pilar Rodriguez
	Maria Alaniz	Sierra Pena
	Kaylan Burke	Sam Saldivar

1. Introductions (HCRMA & HDR only)
2. Project Description
3. Bid Valid for 60 Days from submittal date
4. Bid Opening

Online Virtual Meeting Link

Microsoft Teams meeting

Join on your computer, mobile app or room device

[Click here to join the meeting](#)

Meeting ID: 266 336 329 287

Passcode: ACtinV

[Download Teams](#) | [Join on the web](#)

Or call in (audio only)

[+1 402-513-9026,,925708309#](#) United States, Omaha

[\(833\) 255-2803,,925708309#](#) United States (Toll-free)

Phone Conference ID: 925 708 309#

ATTACHMENT C

Hidalgo County Regional Mobility Authority Granjeno Wetland Mitigation Project (Re-Bid No. 2024-004)

#1	2/20/2024 4:21 PM	Would it be possible to get the digital dwg files for the existing surface and designed contours? Our initial engineering review appears to show a dirt imbalance based on the limited lidar data publicly available.
	3/05/2024 11:43 PM	<p>The digital dwg files for existing surface and finished grade can be provided to bidders. In order to receive the files, a bidder must sign an Electronic Media Release Form. The Form can be requested via e-mail to the following addresses: samuel.saldivar@hdrinc.com, hunter.balbin@hdrinc.com, and sierra.pena@hdrinc.com. The deadline for requesting this information is March 8, 2024.</p> <p>Addendum 1 will be issued to add Bid Item "Embankment (Subbase)". While geotechnical data indicates adequate on-site soil quantities for the clay liner and planting soil strata, the Bidder is responsible for evaluating the quantity of soil (meeting specifications) to import for use as a subbase prior to placing the clay liner. All embankment bid items are required to achieve the design finish grade.</p>
#2	2/28/2024 12:59 PM	The security fence calls for schedule 80 material; this is proving to be somewhat scarce and quite expensive. Would you be open to substituting commercial grade schedule 40 material?
	3/05/2024 11:43 PM	Yes, we will consider substitutes. The Contractor will be required to submit material specifications for the Authority to evaluate and approve a substitute for schedule 80 material.
#3	3/05/2024 11:39 PM	Are bidders who visited the Granjeno Wetland Mitigation site during Bid No. 2023-001 required to visit the site again?
	3/05/2024 11:44 PM	As long as bidders who previously visited the Granjeno Wetland Mitigation site have their visit documented with the Authority, they are not required to visit the site again.

Item No.	Description	Unit Measure	Quantity	Engineer's Unit Price	Engineer's Total Cost	Bid Quantity	MitRes Services Unit Price	MitRes Services Total Cost	Percent Higher Than Engineer's Estimate %
A-1	Mobilization/Demobilization (including bonds and insurance)	LS	1.00	\$ 155,991.04	\$ 155,991.04	1.00	\$ 497,611.09	\$ 497,611.09	219.00%
A-2	Well and Pump - 550GPM Capacity (including site pad, grading, building, new power connection, instrumentation, controls, and integration)	LS	1.00	\$ 475,000.00	\$ 475,000.00	1.00	\$ 977,100.65	\$ 977,100.65	105.71%
A-3	Planting (procurement, storage, delivery, installation, protection, maintenance)	LS	1.00	\$ 100,000.00	\$ 100,000.00	1.00	\$ 102,974.50	\$ 102,974.50	2.97%
A-4	Storm Water Pollution Prevention Plan (permitting, installation, maintenance, removal)	LS	1.00	\$ 31,250.00	\$ 31,250.00	1.00	\$ 63,453.98	\$ 63,453.98	103.05%
<i>Total of All Lump Sum Bid Items</i>					\$ 762,241.04			\$ 1,641,140.22	115.30%
B-1	6" PVC Waterline	LF	2,700	\$ 93.75	\$ 253,125.00	2,700	\$ 311.92	\$ 842,184.00	232.71%
B-2	Excavation	CY	178,000	\$ 12.50	\$ 2,225,000.00	178,000	\$ 5.90	\$ 1,050,200.00	-52.80%
B-3	Embankment (Planting Soil)	CY	73,000	\$ 11.25	\$ 821,250.00	73,000	\$ 1.41	\$ 102,930.00	-87.47%
B-4	Embankment (Clay Liner)	CY	87,000	\$ 11.25	\$ 978,750.00	87,000	\$ 0.68	\$ 59,160.00	-93.96%
B-5	Embankment (Subbase)	CY	110,000	\$ 11.25	\$ 1,237,500.00	110,000	\$ 14.79	\$ 1,626,900.00	31.47%
B-6	Clearing/ Grubbing	AC	25	\$ 1,500.00	\$ 37,500.00	25	\$ 3,476.45	\$ 86,911.25	131.76%
B-7	Grate Inlet	EA	1	\$ 3,750.00	\$ 3,750.00	1	\$ 31,500.00	\$ 31,500.00	740.00%
B-8	18" RCP	LF	100	\$ 106.25	\$ 10,625.00	100	\$ 2,461.42	\$ 246,142.00	2216.63%
B-9	15' Wide Access Road	SY	7,000	\$ 31.25	\$ 218,750.00	7,000	\$ 28.04	\$ 196,280.00	-10.27%
<i>Total of All Unit Cost Bid Items</i>					\$ 5,786,250.00			\$ 4,242,207.25	-26.68%
TOTAL					\$ 6,548,491.04			\$ 5,883,347.47	-10.16%

Bid prices appear to be mathematically unbalanced, be front loaded, and includes token bid prices with the embankment.



Office of the Secretary of State

CERTIFICATE OF FILING OF

MitRes Services, LLC
File Number: 805114465

The undersigned, as Secretary of State of Texas, hereby certifies that an Application for Registration for the above named Foreign Limited Liability Company (LLC) to transact business in this State has been received in this office and has been found to conform to the applicable provisions of law.

ACCORDINGLY, the undersigned, as Secretary of State, and by virtue of the authority vested in the secretary by law, hereby issues this certificate evidencing the authority of the entity to transact business in this State from and after the effective date shown below for the purpose or purposes set forth in the application under the name of

MitRes Services, LLC

The issuance of this certificate does not authorize the use of a name in this state in violation of the rights of another under the federal Trademark Act of 1946, the Texas trademark law, the Assumed Business or Professional Name Act, or the common law.

Dated: 06/16/2023

Effective: 06/16/2023

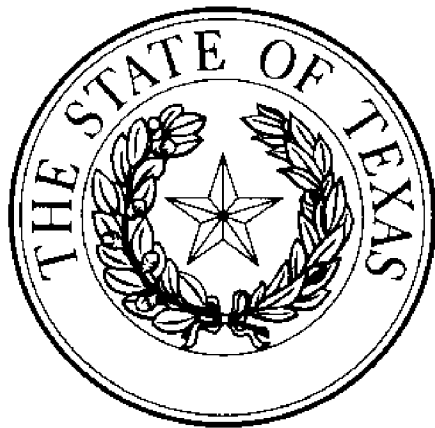

A handwritten signature in black ink that reads "Jane Nelson".

Jane Nelson
Secretary of State

**Form 304
(Revised 05/11)**

Submit in duplicate to:
Secretary of State
P.O. Box 13697
Austin, TX 78711-3697
512 463-5555
FAX: 512/463-5709
Filing Fee: \$750

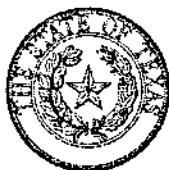

This space reserved for office use.

**Application for
Registration
of a Foreign Limited
Liability Company**

1. The entity is a foreign limited liability company. The name of the entity is:

MitRes Services, LLC

Provide the full legal name of the entity as stated in the entity's formation document in its jurisdiction of formation.

2A. The name of the entity in its jurisdiction of formation does not contain the word "limited liability company" or "limited company" (or an abbreviation thereof). The name of the entity with the word or abbreviation that it elects to add for use in Texas is:

2B. The entity name is not available in Texas. The assumed name under which the entity will qualify and transact business in Texas is:

The assumed name must include an acceptable organizational identifier or an accepted abbreviation of one of these terms.

3. Its federal employer identification number is: 92-1995158

Federal employer identification number information is not available at this time.

4. It is organized under the laws of: (set forth state or foreign country) Nevada

and the date of its formation in that jurisdiction is: 01/11/2023

mm/dd/yyyy

5. As of the date of filing, the undersigned certifies that the foreign limited liability company currently exists as a valid limited liability company under the laws of the jurisdiction of its formation.

6. The purpose or purposes of the limited liability company that it proposes to pursue in the transaction of business in Texas are set forth below.

Environmental consulting services (land reclamation and wetland restoration planning services)

The entity also certifies that it is authorized to pursue such stated purpose or purposes in the state or country under which it is organized.

7. The date on which the foreign entity intends to transact business in Texas, or the date on which the foreign entity first transacted business in Texas is: 06/12/2023

mm/dd/yyyy

Late fees may apply (see instructions).

8. The principal office address of the limited liability company is:

5340 Legacy Dr., Bldg. 1, Ste. 300 Plano

TX

USA

75024

Address

City

State

Country

Zip/Postal Code

Complete item 9A or 9B, but not both. Complete item 9C.

9A. The registered agent is an organization (cannot be entity named above) by the name of:

Corporation Service Company d/b/a CSC-Lawyers Incorporating Service Company

OR

9B. The registered agent is an individual resident of the state whose name is:

<i>First Name</i>	<i>M.I.</i>	<i>Last Name</i>	<i>Suffix</i>	
-------------------	-------------	------------------	---------------	--

9C. The business address of the registered agent and the registered office address is:

211 E. 7th Street, Suite 620	Austin	TX	78701-3218	
<i>Street Address</i>	<i>City</i>	<i>State</i>	<i>Zip Code</i>	

10. The entity hereby appoints the Secretary of State of Texas as its agent for service of process under the circumstances set forth in section 5.251 of the Texas Business Organizations Code.

11. The name and address of each governing person is:

NAME AND ADDRESS OF GOVERNING PERSON (Enter the name of either an individual or an organization, but not both.)				
IF INDIVIDUAL				
John	C.	Butler	Jr.	
<i>First Name</i>	<i>M.I.</i>	<i>Last Name</i>	<i>Suffix</i>	
OR				
IF ORGANIZATION				
<i>Organization Name</i>				
5340 Legacy Drive, Bldg 1, Suite 300	Plano	TX	USA	75024
<i>Street or Mailing Address</i>	<i>City</i>	<i>State</i>	<i>Country</i>	<i>Zip Code</i>

NAME AND ADDRESS OF GOVERNING PERSON (Enter the name of either an individual or an organization, but not both.)				
IF INDIVIDUAL				
Carroll	L.	Dewing		
<i>First Name</i>	<i>M.I.</i>	<i>Last Name</i>	<i>Suffix</i>	
OR				
IF ORGANIZATION				
<i>Organization Name</i>				
5340 Legacy Drive, Bldg 1, Suite 300	Plano	TX	USA	75024
<i>Street or Mailing Address</i>	<i>City</i>	<i>State</i>	<i>Country</i>	<i>Zip Code</i>

NAME AND ADDRESS OF GOVERNING PERSON (Enter the name of either an individual or an organization, but not both.)				
IF INDIVIDUAL				
John	D.	Neumann		
<i>First Name</i>	<i>M.I.</i>	<i>Last Name</i>	<i>Suffix</i>	
OR				
IF ORGANIZATION				
<i>Organization Name</i>				
5340 Legacy Drive, Bldg 1, Suite 300	Plano	TX	USA	75024
<i>Street or Mailing Address</i>	<i>City</i>	<i>State</i>	<i>Country</i>	<i>Zip Code</i>

Supplemental Provisions/Information

Text Area: [The attached addendum, if any, is incorporated herein by reference.]

Additional Governing Persons:

J. Patrick Sullivan, Jr.; 5340 Legacy Drive, Bldg 1, Suite 300, Plano, TX 75024

Eric S. Anderson; 5340 Legacy Drive, Bldg 1, Suite 300, Plano, TX 75024

Effectiveness of Filing (Select either A, B, or C.)

A. This document becomes effective when the document is filed by the secretary of state.

B. This document becomes effective at a later date, which is not more than ninety (90) days from the date of signing. The delayed effective date is: _____

C. This document takes effect upon the occurrence of a future event or fact, other than the passage of time. The 90th day after the date of signing is: _____

The following event or fact will cause the document to take effect in the manner described below:

Execution

The undersigned affirms that the person designated as registered agent has consented to the appointment. The undersigned signs this document subject to the penalties imposed by law for the submission of a materially false or fraudulent instrument and certifies under penalty of perjury that the undersigned is authorized under the provisions of law governing the entity to execute the filing instrument.

Date: 06/12/2023



Signature of authorized person (see instructions)

Matthew J. Dilluvio, Assistant Secretary
Printed or typed name of authorized person.

Form 401-A
(Revised 12/09)



**Acceptance of Appointment
and
Consent to Serve as Registered Agent
§5.201(b) Business Organizations Code**

The following form may be used when the person designated as registered agent in a registered agent filing is an individual.

Acceptance of Appointment and Consent to Serve as Registered Agent

I acknowledge, accept and consent to my designation or appointment as registered agent in Texas for

Name of represented entity

I am a resident of the state and understand that it will be my responsibility to receive any process, notice, or demand that is served on me as the registered agent of the represented entity; to forward such to the represented entity; and to immediately notify the represented entity and submit a statement of resignation to the Secretary of State if I resign.

x:

Signature of registered agent

Printed name of registered agent

Date (mm-dd/yyyy)

The following form may be used when the person designated as registered agent in a registered agent filing is an organization.

Acceptance of Appointment and Consent to Serve as Registered Agent

I am authorized to act on behalf of Corporation Service Company d/b/a CSC-Lawyers Incorporating Service Company
Name of organization designated as registered agent

The organization is registered or otherwise authorized to do business in Texas. The organization acknowledges, accepts and consents to its appointment or designation as registered agent in Texas for:

MitRes Services, LLC

Name of represented entity

The organization takes responsibility to receive any process, notice, or demand that is served on the organization as the registered agent of the represented entity; to forward such to the represented entity; and to immediately notify the represented entity and submit a statement of resignation to the Secretary of State if the organization resigns.

x: By:

Jerome L. Suarez

Jerome L. Suarez
Assistant Secretary

06/15/2023

Signature of person authorized to act on behalf of organization

Printed name of authorized person

Date (mm/dd/yyyy)

Corporation Service Company d/b/a CSC-Lawyers Incorporating Service Company



Item No.	Description	\$
A-1	Mobilization and Demobilization	\$ 497,611.09
A-2	Well and Pump - 550GPM Capacity (including site pad, grading, building, new power connection, instrumentation, controls, and integration)	\$ 977,100.65
A-3	Planting (procurement, storage, delivery, installation, protection, maintenance)	\$ 102,974.50
A-4	Storm Water Pollution Prevention Plan (permitting, installation, maintenance, removal)	\$ 63,453.98
Total of All Lump Sum Bid Items		\$ 1,641,140.23

Item No.	Description	Unit	Estimated Quantity	Bid Unit Price	Bid Amount
B-1	6-inch PVC Waterline	LF	2,700	\$ 311.92	\$ 810,686.59
B-2	Excavation	CY	178,000	\$ 5.90	\$ 1,050,223.19
B-3	Embankment (Planting Soil)	CY	73,000	\$ 1.41	\$ 102,940.98
B-4	Embankment (Clay Liner)	CY	87,000	\$ 0.68	\$ 58,746.18
B-5	Embankment (Subbase)	CY	110,000	\$ 14.79	\$ 1,626,428.57
B-6	Clearing / Grubbing	AC	25	\$ 3,476.45	\$ 86,911.16
B-7	Grate Inlet	EA	1	\$ 31,500.00	\$ 31,500.00
B-8	18-inch RCP	LF	100	\$ 2,461.42	\$ 246,141.64
B-9	15-foot wide Access Road	SY	7,000	\$ 28.04	\$ 196,275.33
Total of All Unit Price Bid Items					\$ 4,209,853.64

Total Bid Price (Total of all Lump Sum and Unit Price Bids)	\$ 5,850,993.87
---	-----------------



March 13, 2024

Pilar Rodriguez, PE, Executive Director
Hidalgo County Regional Mobility Authority
203 W. Newcombe Ave
Pharr, Texas 78577

Dear Mr. Rodriguez,

With great pride and excitement, we **submit** our response to the Hidalgo County Regional Mobility Authority (HCRMA) Request for Sealed Bids on behalf of MitRes Services, a wholly-owned subsidiary of Mitigation Resources of North America (MRNA).

We have carefully assembled a team of our own Texas-based employees that leverages engineering, permitting, and construction professionals with in-depth knowledge of the ecosystem and environment. Our team is nationally recognized for successfully delivering large-scale stream and wetland restoration. In addition, in September 2022, the Railroad Commission of Texas (RCT) selected us as its preferred vendor for large-scale abandoned mine land restoration work throughout the State of Texas. We recently completed a restoration project for RCT in Bastrop on time and budget. We believe this, along with our many successful projects listed below, demonstrates that our team is highly experienced, fully equipped and able to deliver the highest-quality results to HCRMA on time and budget.

Three key strengths frame our qualifications for this effort:

- The **experience** of our team, both locally and nationally
- **Certainty** and accountability
- A commitment to **client service**

First, **experience**: Our project team has a significant track record of delivering successful mitigation services to large-scale infrastructure projects, including restoring over 359,000 linear feet of streams and over 1,500 acres of wetlands. In Texas alone, we have planted 9.1 million trees and 18,300 acres of native grasses. Additionally, we have extensive local networks, relationships with key partners, and experience implementing best practices in community engagement that allow us to execute projects promptly and cost-effectively. Notably, we have foundational working relationships with the U.S. Army Corps of Engineers (USACE) and institutional knowledge that will aid in project efficiency and success.

Second, **certainty**: Providing certainty for our clients is a shared value across the MitRes Services team. We hold ourselves accountable for a fair, fixed-price commitment to full delivery. While we recognize the dynamic nature of mitigation work often creates uncertainty, our financial structure (parent company with over \$80 million in cash and minimal debt) ensures we can fully absorb project costs when unanticipated barriers to progress arise and remove mitigation liability from our clients. We pride ourselves on our ability to prevent budgetary bottlenecks from impeding timely progress and not burdening our clients with unexpected costs or delays.

Third, **client service**: We are committed to maximizing local labor to ensure our team is highly skilled, responsive, and “on call” to serve as an extension and steward of HCRMA. We recognize the value in employing those who know the landscape, people, and nuances of the area while being readily available at all times. Further, we view our clients as team members and institute these practices into all aspects of our workflow. We believe client service should not be added value but a critical component of project success. From detailed progress reports, consistent and proactive communication, and adequate systems to track milestones, we pride ourselves on fostering relationships with clients built on candor. You can expect consistency, transparency, and collaboration in decision-making, problem-solving, and project progression – without surprises or superfluous change orders.

We appreciate the opportunity to submit a response. After reviewing the digital design files, **our assessment suggests a deficiency of 110,000 cubic yards of available material needed to complete the project. Our bid includes hauling in suitable material from offsite. Our proposal assumes that this material consists of 59% Clay (Caliche) and 41% Planting Soil per the HCMRA’s engineer’s recommendation. If a mutual agreement is reached confirming that the required material is or will be on-site rather than needing to be hauled in, the total bid price could be decreased.**

As a deeply experienced, leading Texas-based restoration and mitigation deliverer, MitRes Services is well-positioned to provide the engineering, design, construction, monitoring, and day-to-day management to meet HCRMA’s needs.

Thank you for your time and consideration,



Eric Anderson
President
MitRes Services, LLC

Workload and Staffing**Project Delivery Team:**

Position	Personnel Name	Years of Experience Performing Role	Years with Company
Project Executive/Principal-in-Charge	Eric Anderson	20	20
Project Manager (Design and Construction phases)	Drew Haley	15	11
Project Manager (Monitoring and Maintenance phases)	Drew Haley	15	11
Construction Superintendent	Jon Phillips	20	10
Safety Manager	Roman Quinn	9	5
QA/QC Manager	Drew Haley	11	11

MitRes Services has sufficient workforce capacity to perform the services and exceed expectations in service delivery and quality.

The MitRes team of 30 professionals with specialties in ecological restoration, project finance, project and construction management, and real estate – are all available to be involved in the project. The team has diverse and complementary skills to encompass all disciplines and aspects of restoration.

Additionally, the majority of our environmental professionals and construction personnel are located in Texas and will be readily available for this effort – supplying the local labor force who are equipped with advantageous knowledge of the Hidalgo County environment, ecosystem, and communities. MitRes Services and its affiliated companies include over 120 engineering and environmental professionals along with 20 Texas-based experienced earthwork supervisors to call upon for the execution of this project.

General Company information.

Contact Information:

Company Name:	Mitigation Resources of North America		
Physical Address:	209 Renaissance Drive		
Mailing Address:	209 Renaissance Drive		
City:	Hallsville	State/Zip:	TX 75650
Telephone:	(903) 660-7527	Fax:	N/A
Primary Contact Name:	Eric Anderson, President		
Primary Contact Email:	Eric.anderson@mitigate.pro		
Secondary Contact Name:	Leland Starks, Vice President of Mitigation Solutions		
Secondary Contact Email:	Leland.starks@mitigate.pro		

Representative Projects:

Project Name	Owner Agency	Current Project Phase (designate as Design, Construction, or Monitoring)	Contract Value	Expected Completion Date	Description of Work
Tobaksákola Mitigation Project - PRM	Mississippi Lignite Mining Company	Complete	\$10,100,000	Construction: Fall 2022 Monitoring: 2028	Stream restoration and stream buffer enhancement
Tobaksákola Phase II Mitigation Project - PRM	Mississippi Lignite Mining Company	Complete	\$8,300,000	Construction: Fall 2022 Monitoring: 2028	Stream restoration and stream buffer enhancement

Yockanookany Mitigation Bank	Yockanookany Mitigation Resources, LLC	Construction	\$12,200,000	Construction: Winter 2020 Monitoring: 2031	Stream restoration, stream buffer enhancement, wetland enhancement, and wetland preservation
Lye Branch Mitigation Bank	Mitigate Alabama, LLC	Construction	\$5,400,000	Construction: Winter 2022 Monitoring: 2032	Stream restoration, stream buffer enhancement, and wetland enhancement
Smoky Run Mitigation Bank	Mitigate Tennessee, LLC	Complete	\$9,200,000	Construction: Winter 2020 Monitoring: 2031	Stream restoration, stream buffer enhancement, wetland enhancement, and wetland preservation
Cave Spring Mitigation Bank	Mitigate Tennessee, LLC	Complete	\$2,500,000	Construction: Winter 2022 Monitoring: 2032	Stream restoration, stream buffer enhancement, and wetland enhancement
Battle Ridge Mitigation Bank	Mitigate Tennessee, LLC	Design	\$15,200,000	Construction: Winter 2024 Monitoring: 2032	Stream restoration, stream buffer enhancement, and wetland enhancement
Buffalo Valley Mitigation Bank	Mitigate Tennessee, LLC	Design	\$8,100,000	Construction: Winter 2024 Monitoring: 2032	Stream restoration, stream buffer enhancement, and wetland enhancement
Whites Creek Mitigation Bank	Mitigate Texas, LLC	Design	\$13,000,000	Construction: Winter 2024 Monitoring: 2032	Stream restoration, stream buffer enhancement, and wetland enhancement
Pomona Mitigation Bank	Mitigate Florida, LLC	Design	\$13,200,000	Construction: Winter 2026 Monitoring: 2036	Wetland restoration and enhancement

Invasive Species Management:

As per 4.2.2.2 of the Draft Mitigation Plan (plan), bermudagrass is currently established throughout the site and treatment with glyphosate is proposed. Additional invasives observed during the November 28, 2023, site visit includes buffelgrass (*Cenchrus ciliaris*), king ranch bluestem (*Bothriochloa ischaemum*) and salt cedar (*Tamarix ramosissima*). Similarly problematic aggressive native species included retama (*Parkinsonia aculeata*), honey mesquite (*Prosopis glandulosa*) and huisache (*Vachellia farnesiana*). Although native, these species establish very quickly in disturbed areas and often increase competition resulting in reduced diversity. Herbicide treatments alone for the bermudagrass, buffelgrass and KR bluestem alike have been proven ineffective in drastically reducing plant densities. These invasive and aggressive natives are considered undesirable when re-establishing a diverse native plant community. Accordingly, additional measures are proposed to control these species more effectively by reducing accumulated seedbank stores. This process of seedbank mining requires multiple treatments which in combination are more effective than herbicide alone.

The following sequence of treatment is proposed to reduce invasive seedbank stores prior to planting. For best results, this treatment is typically administered over a two-year period, however this process may be conducted in a single year if rainfall is adequate to stimulate seedbank germination before and after each treatment. If flood irrigation is practical, this measure may be used to promote seedbank germination and enhance results.

- (1) whole-field application of non-selective herbicide post emergence of seedbank (Mar-Apr)
- (2) summer prescribed burn of desiccated plant residues (Apr-May)
- (3) shallow disking (≤ 2 inches) (Apr-May)
- (4) a secondary whole field application of non-selective herbicide (May-July)
- (5) individual plant treatment (IPT) of woody invasives & aggressive natives (May-July)
- (6) seeding with a no-till drill into standing plant stubble (Aug 15-Oct 15)

With adequate rainfall, undesired species are likely to re-establish quickly. Therefore, initial whole-field herbicide treatment (Step 1) may be possible 3 to 4 weeks following final grading. Seedbank stores will be allowed to develop adequate growth prior to Step 1 for (1) maximum kill results from herbicide treatment and (2) development of adequate fine fuel for prescribed summer burning. If inadequate fine fuel results from the initial growth and herbicide application, Step 2 will not be administered. Disking to promote seedbank development will be limited to the top 2 inches of topsoil. IPT of seedling woody species shall be performed as needed following Step 4. In addition to herbicide, disking and burning, the following planting methods will reduce potential of undesirable species establishment. Competition from planted desirable species will minimize establishment of undesired species. To maximize establishment of native permanent cover, annual forbs and cover crops will be excluded from initial planting mixes. Cover crops will be added to seed blends only if warranted due to seasonal planting limitations or increased erosion potential. Additionally, mulching will be avoided when practical to minimize the introduction of invasive plant materials. Seed will consist of locally adaptive species and fertilization will be avoided to minimize competition from

undesired species. Final seeding will be conducted using a no-till drill to minimize soil disturbance and potential seedbank stimulation. Table X below details the cost associated with the management of invasive species.

Table X Invasive Species Treatment Cost Estimate

Treatment Zone	Acres (approx.)	Treatment				
		Herbicide 1 ¹	Burn ²	Disk ³	Herbicide 2 ⁴	IPT ⁵
Upland, Scrub-shrub (PSS), Emergent (PEM)	29	\$4,495.00	\$0.00	\$3,195.00	\$4,205.00	\$4,495.00
Woodline ⁶	5	\$775.00	\$0.00	\$400.00	\$725.00	\$775.00
	34	\$5,270.00	\$0.00	\$3,595.00	\$4,930.00	\$5,270.00

Footnotes:

1. Whole field application with (3%) 54% glyphosate at a rate of 20 gallons/acre (\$155/ac. includes mobilization)
2. Labor + Water truck + Tractor/disk & subsequent 2" disking (\$875 mobilization + \$80/ac. disking)
3. Seedbank stimulation 2" disking (\$875 mobilization + \$80/ac. disking)
4. Second herbicide application at a lighter rate (\$145/ac. includes mobilization)
5. Individual plant treatment of woody stems + mobilization if needed
6. Optional treatment area if berm structure needed (see mitigation work plan location map).

Revegetation:

Seeding

Seed blends will be derived from plant materials developed specifically for South Texas, and planting rates will follow recommendations by the NRCS for Texas Planting Zone 3 (see Table X below). Planting will be performed with a no-till drill with separated fluffy and slick seedboxes. As recommended by the Cesar Kleberg Wildlife Research Institute South Texas Native program, seeding will be conducted with a no-till drill as early as August 15 through October 15. Seeding will be administered directly into standing plant stubble to minimize potential seedbank stimulation. If needed, treated areas will be mowed prior to planting to ensure ideal seed-to-soil contact.

Woody stocking

As per the Plan, woody stocking will be restricted to a scrub-shrub planting zone along the wetland mitigation area fringe with a mix of species Table 4-3. Woody plant materials will be locally grown and planted at a minimum of 150 stems per acre. Plant materials will consist of a mix of both containerized and bareroot (plugs) plants, with no one species constituting more than 20 percent of the final mix. Irrigation will be used to ensure 70 percent survival by project completion. Woody stocking materials will be locally grown based on seasonal availability. Planting will be conducted during the dormant season from October 1 to March 31,

with targeted peak dormancy from Dec 1 – Feb 15. Woody stocking will be conducted in the immediate winter following final seeding.

Table X Proposed Seeding Cost Estimate

Planting Zone	Acres (approx.)	Native Seeding					
		Seeding (PLS lb./ac.)	Seed (\$/PLS lb.)	Seed (\$/ac.)	Seed (Total \$)	Labor ⁵ (Drill/ac.)	Total Labor
Upland ¹	11	12	\$40.00	\$480.00	\$5,280.00	\$312.00	\$3,432.00
Scrub-shrub (PSS) ²	3	12	\$40.00	\$480.00	\$1,440.00	\$312.00	\$936.00
Emergent (PEM) ³	15	12	\$60.00	\$720.00	\$10,800.00	\$312.00	\$4,680.00
Woodline ⁴	5	12	\$40.00	\$480.00	\$2,400.00	\$312.00	\$1,560.00
					\$19,920.00		\$10,608.00

Footnotes:

1. Seeded with upland mix (Kings South Texas Native Grass Mix)
2. Seeded Douglas King custom blend per Table 4-2 + tree/shrub plugs (locally grown)
3. Seeded Douglas King custom blend per Table 4-2
4. Optional revegetation if berm structure needed (see mitigation work plan location map).
6. Labor cost includes mobilization

Migratory Birds:

During November 28, 2023, site inspection suitable nesting habitats for migratory birds were observed throughout the project area. In compliance with the Migratory Bird Treaty Act of 1918, the US Fish and Wildlife Service and Texas Parks and Wildlife recommend avoidance of clearing suitable nesting habitats during the peak nesting season of March 15 – September 15. Accordingly, clearing will be avoided when practicable during the peak nesting season. However, if clearing is required during peak nesting, MRNA shall perform a nest survey of suitable habitat at the cost of the client. Surveys will be conducted to document any active nest sites by a qualified biologist. Survey results will be provided to the client within 48 hours of completion. Survey results will be considered valid for one week (7 days) of active clearing. In the event that an active nest is found, a 150-foot buffer will be placed around the nest site until young birds have fledged from the nest. This may take 2 to 6 weeks, during which no work will be conducted within the buffer zone. Once all immature birds have fledged, a follow-up survey of the buffer zone will be conducted, and work in the area will resume. MRNA shall not be held accountable for work delays resulting from project scheduling conflicts and compliance with the Migratory Bird Treaty Act.



List of Potential Subcontractors

Blackland Environmental, LLC

8803 Timmerman Cove, Garden Ridge, Texas 78266
Jeremiah McKinney
210-834-4368
jeremiah@bk-land.com

Cosby Mesquite Clearing

908 N County Rd 101, Falfurrias
Joshua Cosby
361-474-3222

Engineering Resources, LLC

P.O. Box 9155, Longview, Texas 75608
Dan Metcalf, P.E.
903-234-4570
dmetcalf@enr-res.com

Novus Electrical Systems, LLC

2601 Arlington Road, Marshall, Texas 75672
Ronnie Holland
903-926-2557
novuselectrical@gmail.com

J and S Water Wells

1056 East First, Bellville, Texas 77418
Shaun Grell
979-865-2393
monterichardson@me.com

Soil Tech Advance, INC

1100 East Hackberry, McAllen, Texas 78501
David Navarro
956-668-7645
STAINC.NET

MitRes Services, LLC
209 Renaissance Dr
Hallsville, TX 75650
903.660.7527
mitigate.pro



A MITIGATION RESOURCES OF NORTH AMERICA COMPANY

Whitaker Plumbing, INC
601 W Wellington St, Carthage, TX 75633
Mark Whitaker
903-693-8866
mark@whitakerplumb.com

MitRes Services, LLC
209 Renaissance Dr
Hallsville, TX 75650
903.660.7527
mitigate.pro



List of Potential Suppliers

Soil Tech Advance, INC

1100 East Hackberry, McAllen, Texas 78501

David Navarro

956-668-7645

STAINC.NET

Delta Fuels

PO Box 737514, Dallas, Texas 75373

Sam Ferguson

(318) 757-7610

[Delta Fuel – Propane, Gas, Diesel & Lubricants](#)

Quintanilla Dirt Work

PO Box 545, Sebastian, Texas 78594

(956) 746-7511

[Quintanilla's Dirt Work | Facebook](#)

1. Bidder and Surety, jointly and severally, bind themselves, their heirs, executors, administrators, successors, and assigns to pay to Owner upon default of Bidder any difference between the total amount of Bidder's Bid and the total amount of the Bid of the next lowest, responsible Bidder that submitted a responsive Bid, as determined by Owner, for the work required by the Contract Documents, provided that:
 - 1.1. If there is no such next Bidder, and Owner does not abandon the Project, then Bidder and Surety shall pay to Owner the bond amount set forth on the face of this Bond, and
 - 1.2. In no event will Bidder's and Surety's obligation hereunder exceed the bond amount set forth on the face of this Bond.
 - 1.3. Recovery under the terms of this Bond will be Owner's sole and exclusive remedy upon default of Bidder.
2. Default of Bidder occurs upon the failure of Bidder to deliver within the time required by the Bidding Documents (or any extension thereof agreed to in writing by Owner) the executed Agreement required by the Bidding Documents and any performance and payment bonds required by the Bidding Documents.
3. This obligation will be null and void if:
 - 3.1. Owner accepts Bidder's Bid and Bidder delivers within the time required by the Bidding Documents (or any extension thereof agreed to in writing by Owner) the executed Agreement required by the Bidding Documents and any performance and payment bonds required by the Bidding Documents, or
 - 3.2. All Bids are rejected by Owner, or
 - 3.3. Owner fails to issue a Notice of Award to Bidder within the time specified in the Bidding Documents (or any extension thereof agreed to in writing by Bidder and, if applicable, consented to by Surety when required by Paragraph 5 hereof).
4. Payment under this Bond will be due and payable upon default of Bidder and within 30 calendar days after receipt by Bidder and Surety of written notice of default from Owner, which notice will be given with reasonable promptness, identifying this Bond and the Project and including a statement of the amount due.
5. Surety waives notice of any and all defenses based on or arising out of any time extension to issue Notice of Award agreed to in writing by Owner and Bidder, provided that the total time for issuing Notice of Award including extensions will not in the aggregate exceed 120 days from Bid due date without Surety's written consent.
6. No suit or action will be commenced under this Bond prior to 30 calendar days after the notice of default required in Paragraph 4 above is received by Bidder and Surety, and in no case later than one year after the Bid due date.
7. Any suit or action under this Bond must be commenced only in a court of competent jurisdiction located in the state in which the Project is located.
8. Notices required hereunder must be in writing and sent to Bidder and Surety at their respective addresses shown on the face of this Bond. Such notices may be sent by personal delivery, commercial courier, or by United States Postal Service registered or certified mail, return receipt requested, postage pre-paid, and will be deemed to be effective upon receipt by the party concerned.
9. Surety shall cause to be attached to this Bond a current and effective Power of Attorney evidencing the authority of the officer, agent, or representative who executed this Bond on behalf of Surety to execute, seal, and deliver such Bond and bind the Surety thereby.
10. This Bond is intended to conform to all applicable statutory requirements. Any applicable requirement of any applicable statute that has been omitted from this Bond will be deemed to be included herein as if set forth at length. If any provision of this Bond conflicts with any applicable statute, then the provision of said statute governs and the remainder of this Bond that is not in conflict therewith continues in full force and effect.
11. The term "Bid" as used herein includes a Bid, offer, or proposal as applicable.

	Travelers Casualty and Surety Company of America Travelers Casualty and Surety Company St. Paul Fire and Marine Insurance Company Farmington Casualty Company
---	--

POWER OF ATTORNEY

KNOW ALL MEN BY THESE PRESENTS: That Travelers Casualty and Surety Company of America, Travelers Casualty and Surety Company, St. Paul Fire and Marine Insurance Company, and Farmington Casualty Company are corporations duly organized under the laws of the State of Connecticut (herein collectively called the "Companies"), and that the Companies do hereby make, constitute and appoint Lori A. Proch of Richfield, OH, their true and lawful Attorney(s)-in-Fact to sign, execute, seal and acknowledge the following bond:

Surety Bond No.: Bid Bond
OR

Principal: MilRes Services LLC
Obligee: Hidalgo County Regional Mobility Authority (HCRMA)

Project Description: 2024-004 - Granjeño Wetland Mitigation Site - HDR Project No. 10334419

IN WITNESS WHEREOF, the Companies have caused this instrument to be signed, and their corporate seals to be hereto affixed, this 21st day of April, 2021.



State of Connecticut

By: *Robert L. Raney*
Robert L. Raney, Senior Vice President

City of Hartford ss.

On this the 21st day of April, 2021, before me personally appeared Robert L. Raney, who acknowledged himself to be the Senior Vice President of each of the Companies, and that he, as such, being authorized so to do, executed the foregoing instrument for the purposes therein contained by signing on behalf of said Companies by himself as a duly authorized officer.

IN WITNESS WHEREOF, I hereunto set my hand and official seal.

My Commission expires the 30th day of June, 2026

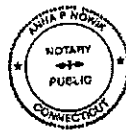

Anna P. Nowik
Anna P. Nowik, Notary Public

This Power of Attorney is granted under and by the authority of the following resolutions adopted by the Boards of Directors of each of the Companies, which resolutions are now in full force and effect, reading as follows:

RESOLVED, that the Chairman, the President, any Vice Chairman, any Executive Vice President, any Senior Vice President, any Vice President, any Second Vice President, the Treasurer, any Assistant Treasurer, the Corporate Secretary or any Assistant Secretary may appoint Attorneys-in-Fact and Agents to act for and on behalf of the Company and may give such appointee such authority as his or her certificate of authority may prescribe to sign with the Company's name and seal with the Company's seal bonds, recognizances, contracts of indemnity, and other writings obligatory in the nature of a bond, recognizance, or conditional undertaking, and any of said officers or the Board of Directors at any time may remove any such appointee and revoke the power given him or her; and it is

FURTHER RESOLVED, that the Chairman, the President, any Vice Chairman, any Executive Vice President, any Senior Vice President or any Vice President may delegate all or any part of the foregoing authority to one or more officers or employees of this Company, provided that each such delegation is in writing and a copy thereof is filed in the office of the Secretary; and it is

FURTHER RESOLVED, that any bond, recognizance, contract of indemnity, or writing obligatory in the nature of a bond, recognizance, or conditional undertaking shall be valid and binding upon the Company when (a) signed by the President, any Vice Chairman, any Executive Vice President, any Senior Vice President or any Vice President, any Second Vice President, any Assistant Treasurer, the Treasurer, any Assistant Secretary or any Assistant Secretary and duly attested and sealed with the Company's seal by a Secretary or Assistant Secretary; or (b) duly executed (under seal, if required) by one or more Attorneys-in-Fact and Agents pursuant to the power prescribed in his or her certificate or their certificates of authority or by one or more Company officers pursuant to a written delegation of authority; and it is

FURTHER RESOLVED, that the signature of each of the following officers: President, any Executive Vice President, any Senior Vice President, any Vice President, any Assistant Vice President, any Secretary, any Assistant Secretary, and the seal of the Company may be affixed by facsimile to any Power of Attorney or to any certificate relating thereto appointing Resident Vice Presidents, Resident Assistant Secretaries or Attorneys-in-Fact for purposes only of executing and attesting bonds and undertakings and other writings obligatory in the nature thereof, and any such Power of Attorney or certificate bearing such facsimile signature or facsimile seal shall be valid and binding upon the Company and any such power so executed and certified by such facsimile signature and facsimile seal shall be valid and binding on the Company in the future with respect to any bond or understanding to which it is attached.

I, Kevin E. Hughes, the undersigned, Assistant Secretary of each of the Companies, do hereby certify that the above and foregoing is a true and correct copy of the Power of Attorney executed by said Companies, which remains in full force and effect.

Dated this 13th day of March, 2024.



Kevin E. Hughes
Kevin E. Hughes, Assistant Secretary

To verify the authenticity of this Power of Attorney, please call us at 1-800-421-3880.
Please refer to the above-named Attorney(s)-in-Fact and the details of the bond to which this Power of Attorney is attached.

Texas Department of Insurance



Certificate No. 11562

Company No. 08-005217

Certificate of Authority

THIS IS TO CERTIFY THAT

TRAVELERS CASUALTY AND SURETY COMPANY OF AMERICA

HARTFORD, CONNECTICUT

has complied with the laws of the State of Texas applicable thereto and is hereby authorized to transact the business of

Fire; Allied Coverages; Hail-growing crops only; Rain; Inland Marine; Ocean Marine; Aircraft--Liability & Physical Damage; Workers' Compensation & Employers' Liability; Employers' Liability; Automobile--Liability & Physical Damage; Liability other than Automobile; Fidelity & Surety; Glass; Burglary & Theft; Forgery; Boiler & Machinery; Credit; Livestock and Reinsurance on all lines authorized to be written on a direct basis

insurance within the state of Texas. This Certificate of Authority shall be in full force and effect until it is revoked, canceled or suspended according to law.

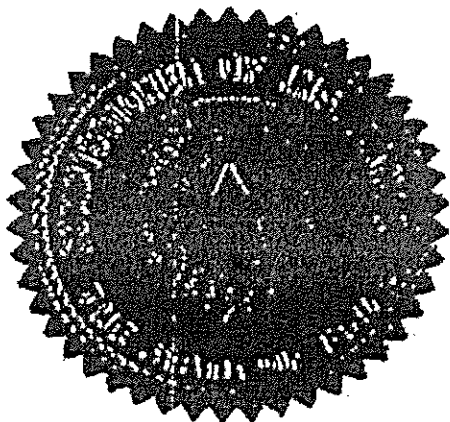

IN TESTIMONY WHEREOF, witness my hand and seal of office at Austin, Texas, this

1st day of July A.D. 1997

ELTON BOMER
COMMISSIONER OF INSURANCE

BY

Kathy A. Wilcox
Director
Insurer Services

ATTACHMENT E

TRAVELERS CASUALTY AND SURETY COMPANY OF AMERICA

HARTFORD, CONNECTICUT 06183

FINANCIAL STATEMENT AS OF JUNE 30, 2023

CAPITAL STOCK \$ 6,480,000

ASSETS		LIABILITIES & SURPLUS	
BONDS	\$ 5,150,661,933	LOSSES	\$ 1,536,742,249
STOCKS	115,760,594	LOSS ADJUSTMENT EXPENSES	136,032,224
CASH AND INVESTED CASH	83,310,786	COMMISSIONS	38,298,447
OTHER INVESTED ASSETS	6,561,822	OTHER EXPENSES	36,588,082
SECURITIES LENDING REINVESTED COLLATERAL ASSETS	25,993,585	TAXES, LICENSES AND FEES	11,726,720
INVESTMENT INCOME DUE AND ACCRUED	43,143,069	UNEARNED PREMIUMS	1,453,378,390
PREMIUM BALANCES	347,718,526	ADVANCE PREMIUM	2,435,053
REINSURANCE RECOVERABLE	43,481,728	POLICYHOLDER DIVIDENDS	18,990,836
NET DEFERRED TAX ASSET	70,753,315	CEDED REINSURANCE NET PREMIUMS PAYABLE	97,783,193
CURRENT FEDERAL AND FOREIGN INCOME TAXES RECOVERABLE	4,319,605	AMOUNTS WITHHELD / RETAINED BY COMPANY FOR OTHERS	21,267,969
GUARANTY FUNDS RECEIVABLE OR ON DEPOSIT	1,369,093	REMITTANCES AND ITEMS NOT ALLOCATED	5,152,800
RECEIVABLE FROM PARENTS, SUBSIDIARIES AND AFFILIATES	26,863,847	PROVISION FOR REINSURANCE	6,464,384
OTHER ASSETS	1,590,021	PAYABLE FOR SECURITIES LENDING	25,993,585
		OTHER ACCRUED EXPENSES AND LIABILITIES	317,899
		TOTAL LIABILITIES	\$ 3,391,171,831
		CAPITAL STOCK	\$ 6,480,000
		PAID IN SURPLUS	433,803,760
		OTHER SURPLUS	2,090,072,333
		TOTAL SURPLUS TO POLICYHOLDERS	\$ 2,530,356,093
TOTAL ASSETS	\$ 5,921,527,924	TOTAL LIABILITIES & SURPLUS	\$ 5,921,527,924

STATE OF CONNECTICUT)
 COUNTY OF HARTFORD) SS.
 CITY OF HARTFORD)

MICHAEL J. DOODY, BEING DULY SWORN, SAYS THAT HE IS VICE PRESIDENT - FINANCE, OF TRAVELERS CASUALTY AND SURETY COMPANY OF AMERICA, AND THAT TO THE BEST OF HIS KNOWLEDGE AND BELIEF, THE FOREGOING IS A TRUE AND CORRECT STATEMENT OF THE FINANCIAL CONDITION OF SAID COMPANY AS OF THE 30TH DAY OF JUNE, 2023.

Michael J. Doody
 VICE PRESIDENT - FINANCE

Susan M. Weissleder
 NOTARY PUBLIC

SUBSCRIBED AND SWORN TO BEFORE ME THIS
 16TH DAY OF AUGUST, 2023

SUSAN M. WEISSLEDER
 Notary Public
 My Commission Expires November 30, 2027

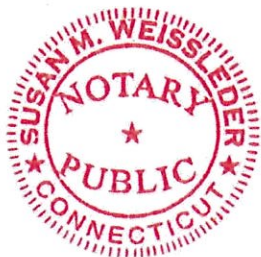

SHEET NO.	DESCRIPTION
1	GENERAL
2	TITLE SHEET
3	PROJECT LAYOUT
4	PROPOSED TYPICAL SECTION
5	GENERAL NOTES
6	ESTIMATE & QUANTITY SHEET
7	SURVEY CONTROL MAP
8	SURVEY BENCHMARK
8	MITIGATION PLANS
9	SITE PLAN
10	BORING LAYOUT
11 - 16	GRADING LAYOUT
17	HORIZONTAL ALIGNMENT DATA
18 - 19	ACCESS ROAD PLAN AND PROFILE
20 - 21	CROSS SECTIONS
22	DRAINAGE
23	DRAINAGE AREA MAP
24	DRAINAGE LATERALS
24	DRAINAGE STANDARDS
25	PB
26	PDD
26	PAZD
27	ELECTRICAL
28	LEGENDS AND ABBREVIATIONS
29	ELECTRICAL LINE DIAGRAM AND DETAILS
30	ELECTRICAL WELL PUMP SITE PLAN
31	ELECTRICAL ENLARGED WELL PUMP SITE PLAN
32	MISCELLANEOUS
33	WELL SITE DETAILS
35	SOILS
36	SOIL MANAGEMENT PLAN
36	SW3P
37	SW3P SHEETS
36 - 38	SW3P STANDARDS
39	EC(1)-16
40	EC(2)-16
41	EC(3)-16
42	EC(5)-16

HIDALGO COUNTY REGIONAL MOBILITY AUTHORITY

PLANS OF PROPOSED WETLAND MITIGATION SITE

CONSTRUCTION OF

A WETLAND MITIGATION SITE CONSISTING OF 26.51 ACRES OF LAND INCLUDING 23.89 ACRES PLANNED SPECIFICALLY OF WETLAND RESTORATION. IMPROVEMENTS INCLUDE DE-COMPACTION OF SOILS, REGRADING, DRAINAGE STRUCTURES, IRRIGATION STRUCTURES, CULVERT STRUCTURES, AND INSTALLATION OF SPECIFIED VEGETATION.

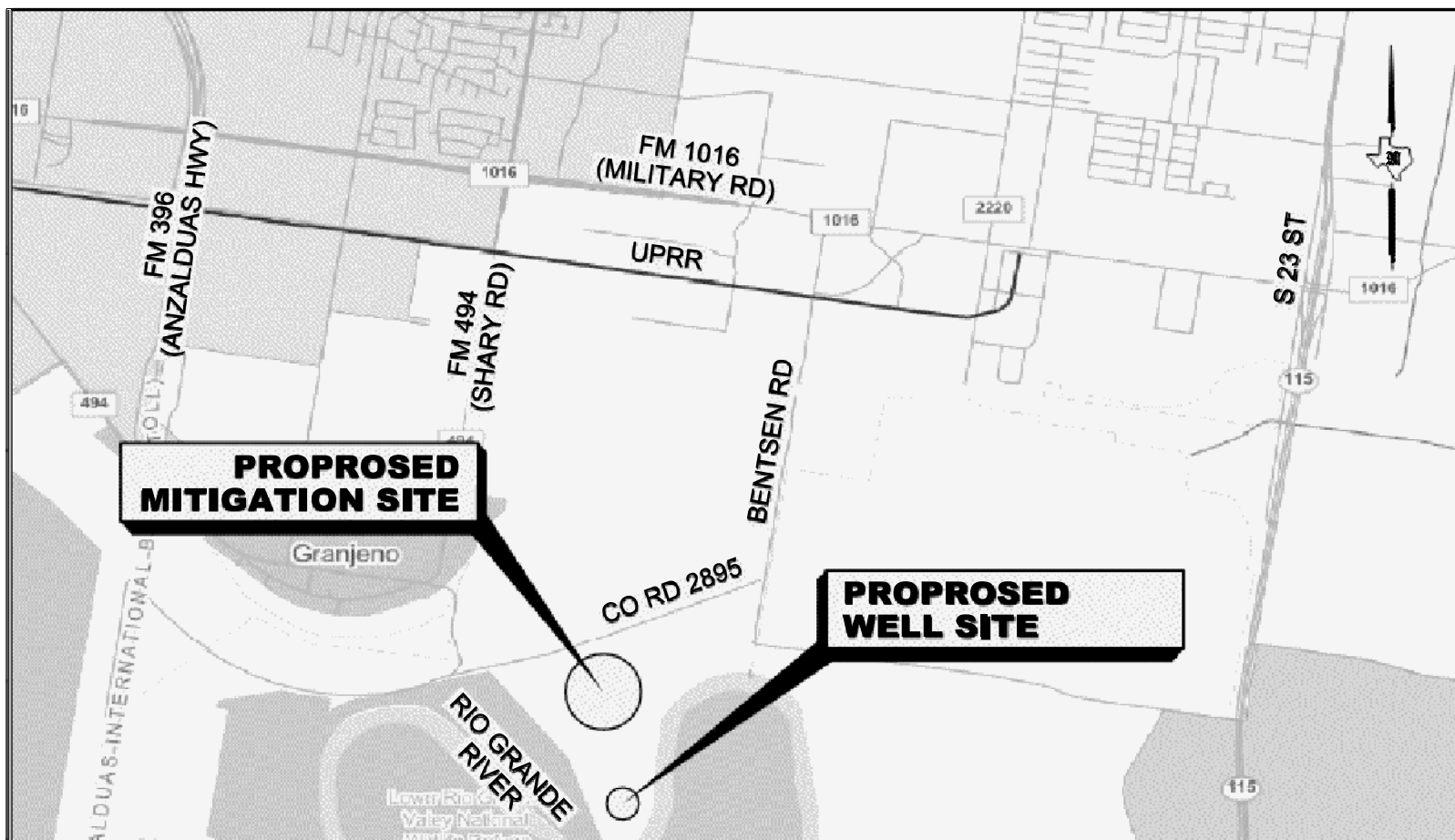
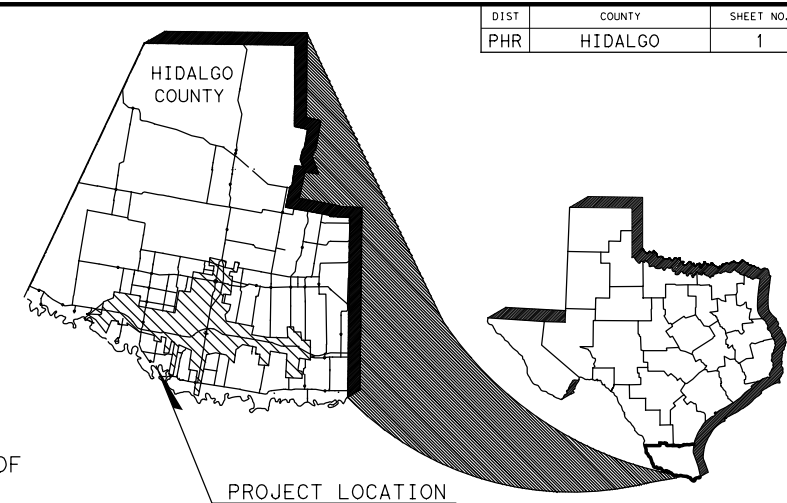

FINAL PLAN DATA :

FINAL CONTRACT PRICE: _____
 CONTRACTORS NAME: _____
 CONTRACTORS ADDRESS: _____
 LETTING DATE: _____
 DATE WORK BEGAN: _____
 DATE WORK COMPLETED: _____
 DATE OF ACCEPTANCE: _____

CHANGE ORDERS & SUPP. AGREEMENTS :

ALL CONSTRUCTION WORK WAS PERFORMED IN ACCORDANCE WITH THE PLANS, SPECIFICATIONS AND CONTRACT. ALL PROPOSED CONSTRUCTION WAS COMPLETED UNLESS OTHERWISE NOTED.

APPROVED FOR LETTING : <input type="checkbox"/>	APPROVED FOR LETTING : <input type="checkbox"/>
<input type="text"/>	<input type="text"/>
HCRMA, CHAIRMAN	HCRMA, EXECUTIVE DIRECTOR
APPROVED FOR LETTING : <input type="checkbox"/>	APPROVED FOR LETTING : <input type="checkbox"/>
<input type="text"/>	<input type="text"/>
HCRMA, CHIEF CONSTRUCTION ENGINEER	HCRMA, CHIEF DEVELOPMENT ENGINEER
SUBMITTED FOR LETTING : <input type="checkbox"/>	
<input type="text"/>	
DANNENBAUM ENGINEERING, PROGRAM MANAGER	

HCRMA

HIDALGO COUNTY REGIONAL MOBILITY AUTHORITY

HCR

HDR
 Firm Registration No. F-754
 4828 Loop Central Drive, Suite 700
 Houston, Texas 77081-2220
 713.622.9264

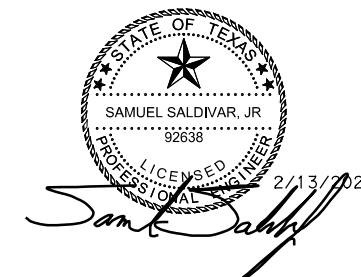

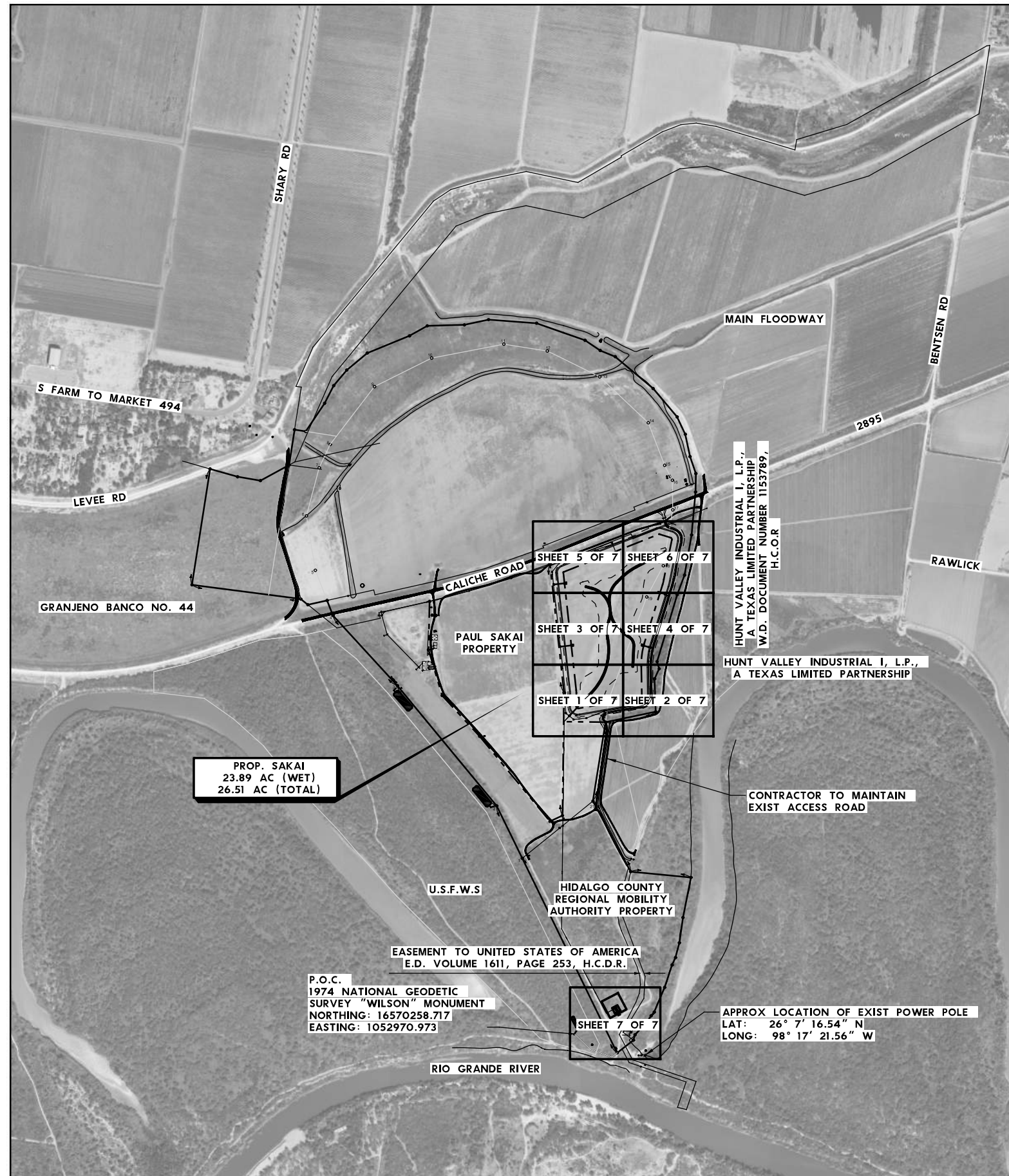

- NOTES:
1. ALL BEARING AND DISTANCES ARE BASED ON THE TEXAS SOUTH COORDINATE SYSTEM (NAD 83), TEXAS SOUTH ZONE.
 2. ALL DISTANCES AND COORDINATE SHOWN ARE SURFACE AND MAY BE CONVERTED TO GRID BY MULTIPLYING BY A COMBINED FACTOR OF 0.999960.
 3. ELEVATION DATUM PER NAVD 88 (GEOID 2003).

BENCHMARK PROVIDED BY: MELDEN & HUNT INC.
 115 W. MCINTYRE
 EDINBURG, TX 78541
 PH: (956)381-0981
 FAX: (956)381-1839

REFERENCE:
 PLAT SHOWING
 TRACT 2 BEGIN 80.201 ACRES CONSISTING OF 38.746 ACRES BEING OUT OF LAS RUELAS BANCO NO. 141 AND 31.964 ACRES BEING THE ACCRETION FROM THE RIO GRANDE RIVER 9.491 ACRES OUT OF LOTS 5, 5A, 6, 16, 7, AND TRACT D AMENDED MAP OF JOHN H. SHARY SUBDIVISION VOLUME 1, PAGES 42-43, H.C.M.R. CITY OF MISSION HIDALGO COUNTY, TEXAS

PROP. SAKAI
 23.89 AC (WET)
 26.51 AC (TOTAL)

HUNT VALLEY INDUSTRIAL I, L.P.,
 A TEXAS LIMITED PARTNERSHIP
 W.D. DOCUMENT NUMBER 1153789,
 H.C.O.R.

HUNT VALLEY INDUSTRIAL I, L.P.,
 A TEXAS LIMITED PARTNERSHIP

CONTRACTOR TO MAINTAIN
 EXIST ACCESS ROAD

EASEMENT TO UNITED STATES OF AMERICA
 E.D. VOLUME 1611, PAGE 253, H.C.D.R.

P.O.C.
 1974 NATIONAL GEODETIC
 SURVEY "WILSON" MONUMENT
 NORTHING: 16570258.717
 EASTING: 1052970.973

APPROX LOCATION OF EXIST POWER POLE
 LAT: 26° 7' 16.54" N
 LONG: 98° 17' 21.56" W

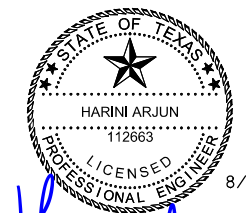

Harini Arjun



HR HDR
 Firm Registration No. F-754
 4828 Loop Central Drive, Suite 800
 Houston, Texas 77081-2220
 713.622.9264

HCRMA GRANJENO
 WETLAND MITIGATION SITE
 PROJECT LAYOUT

SCALE: 1"=1000' SHEET 1 OF 1

DW:			HIGHWAY
CK DW:			365 TOLL
DW:			
CK DW:		DIST	COUNTY
TR:		PHR	HILDAGO
CK TR:			SHEET NO. 2

DATE: 8/2/2022
 FILE: 7072-S-PL0-01

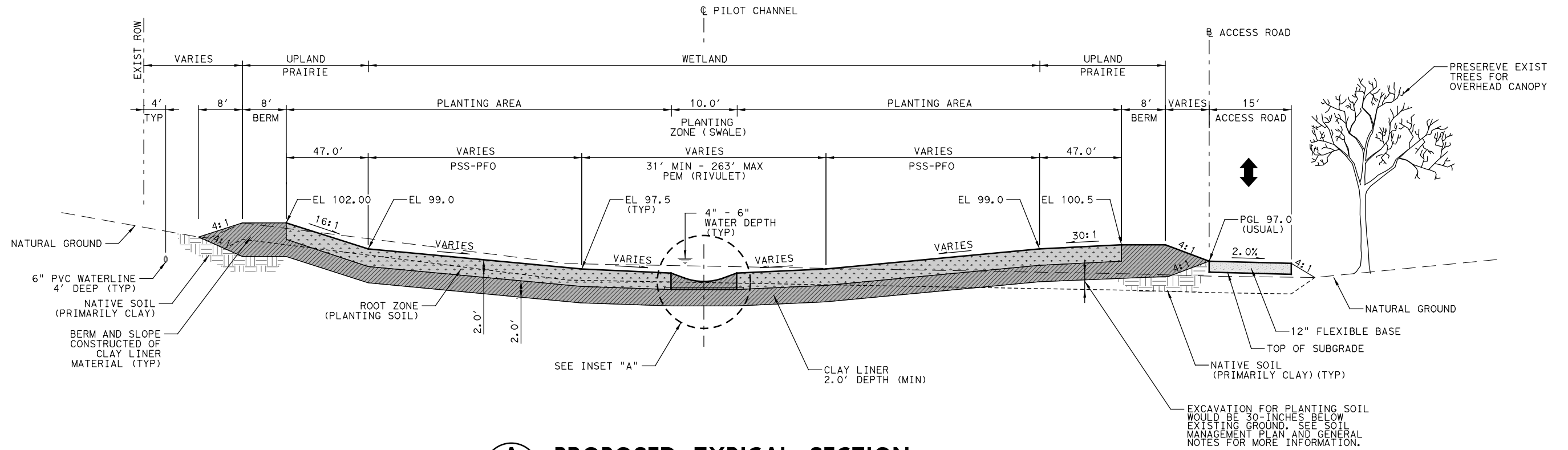

A PROPOSED TYPICAL SECTION

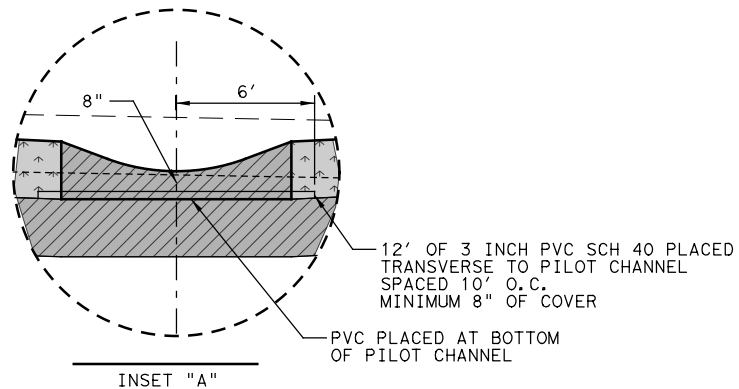

DATE: 10/24/2023
 FILE: Sheet - Typical Section Sheet

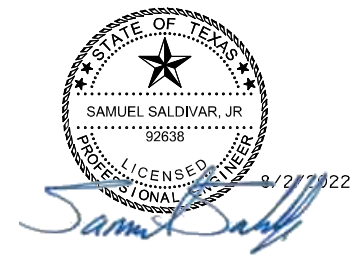

HDR
 HDR
 Firm Registration No. F-754
 4828 Loop Central Drive, Suite 800
 Houston, Texas 77081-2220
 713.622.9264

**HCRMA GRANJENO
 WETLAND MITIGATION SITE
 PROPOSED TYPICAL SECTIONS**

SCALE: N. T. S.		SHEET 1 OF 1	
DN:		HIGHWAY	
CK DN:		365 TOLL	
DW:		DIST:	COUNTY:
CK DW:		PHR:	HILDAGO
TR:		SHEET NO.	
CK TR:		3	